

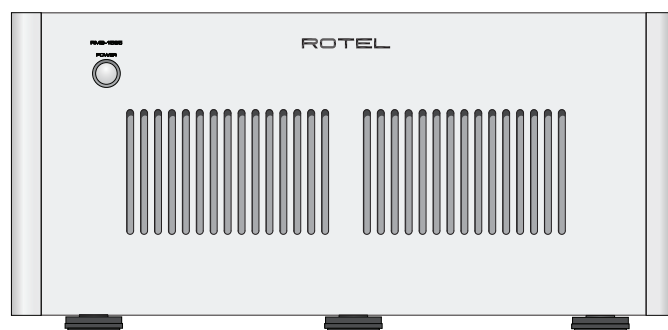

ROTEL®



RMB-1555 / RMB-1585

Five Channel Power Amplifiers

多声道后置放大器

Owner's Manual
使用说明书

Important Safety Instructions

WARNING: There are no user serviceable parts inside. Refer all servicing to qualified service personnel.

WARNING: To reduce the risk of fire or electric shock, do not expose the unit to moisture or water. Do not expose the unit to dripping or splashing. Do not place objects filled with liquids, such as vases, on the unit. Do not allow foreign objects to get into the enclosure. If the unit is exposed to moisture, or a foreign object gets into the enclosure, immediately disconnect the power cord from the wall. Take the unit to a qualified service person for inspection and necessary repairs.

Read all the instructions before connecting or operating the component.

Keep this manual so you can refer to these safety instructions.

Heed all warnings and safety information in these instructions and on the product itself. Follow all operating instructions.

Clean the enclosure only with a dry cloth or a vacuum cleaner.

Do not use this unit near water.

You must allow a minimum 10 cm or 4 inches of unobstructed clearance around the unit.

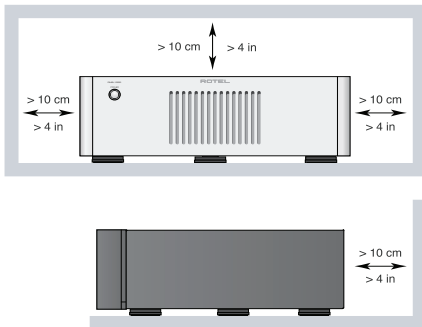

Do not place the unit on a bed, sofa, rug, or similar surface that could block the ventilation openings. If the unit is placed in a bookcase or cabinet, there must be ventilation of the cabinet to allow proper cooling.

Keep the component away from radiators, heat registers, stoves, or any other appliance that produces heat.

WARNING: The rear panel power cord connector is the mains power disconnect device. The device must be located in an open area that allows access to the cord connector.

The unit must be connected to a power supply only of the type and voltage specified on the rear panel. (USA: 120 V/60Hz, EC: 230V/50Hz)

Connect the component to the power outlet only with the supplied power supply cable or an exact equivalent. Do not modify the supplied cable. A polarized plug has two blades, with one wider than the other. A grounding plug has two blades plus a third grounding prong. These are provided for your safety. Do not defeat grounding and/or polarization safety provisions. If the supplied plug does not fit your outlet, please consult an electrician for replacement of the obsolete outlet. Do not use extension cords.

The main plug of the power cordset is a disconnect device of the apparatus. In order to completely disconnect the apparatus from the supply mains, the main plug of the power cordset should be unplugged from the mains (AC) outlet. The stand-by LED indicator will not be lit up to show the power cord is unplugged. The disconnect device shall remain readily operable.

Do not route the power cord where it will be crushed, pinched, bent, exposed to heat, or damaged in any way. Pay particular attention to the power cord at the plug and where the cord exits the back of the unit.

The power cord should be unplugged from the wall outlet during a lightning storm or if the unit is to be left unused for a long period of time.

This apparatus shall be connected to a main socket outlet with a protective earth connection.

Use only accessories specified by the manufacturer.

Use only with a cart, stand, rack, bracket or shelf system recommended by Rotel. Use caution when moving the unit in a stand or rack to avoid injury from a tip-over.



Use Class 2 wiring for speaker connections to ensure proper insulation and minimize the risk of electric shock.

Immediately stop using the component and have it inspected and/or serviced by a qualified service agency if:

- The power supply cord or plug has been damaged.
- Objects have fallen or liquid has been spilled into the unit.
- The unit has been exposed to rain.
- The unit shows signs of improper operation.
- The unit has been dropped or damaged in any way.

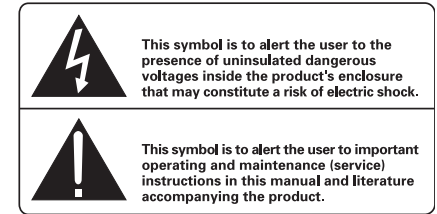
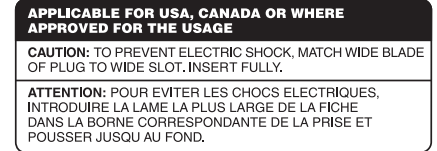

Rotel products are designed to comply with international directives on the Restriction of Hazardous Substances (RoHS) in electrical and electronic equipment and the disposal of Waste Electrical and Electronic Equipment (WEEE). The crossed wheeled bin symbol indicates compliance and that the products must be appropriately recycled or processed in accordance with these directives.

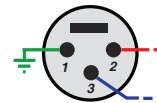

Pin Assignments
Balanced Audio (3 pole XLR):
Pin 1: Ground / Screen
Pin 2: In phase / +ve / Hot
Pin 3: Out of phase / -ve / Cold



Figure 1-1: RMB-1555 Controls and Connections

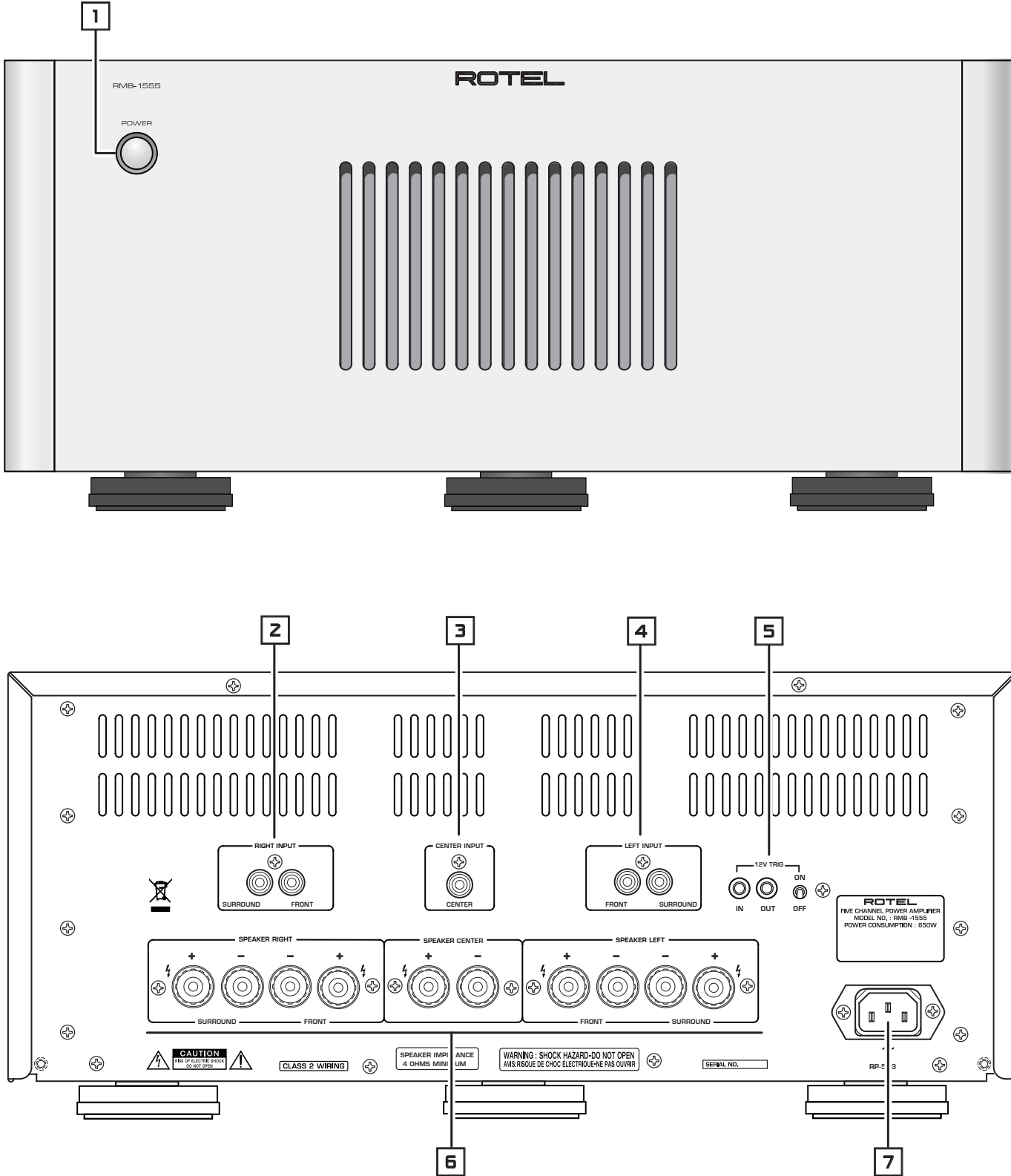

Figure 1-2: RMB-1585 Controls and Connections

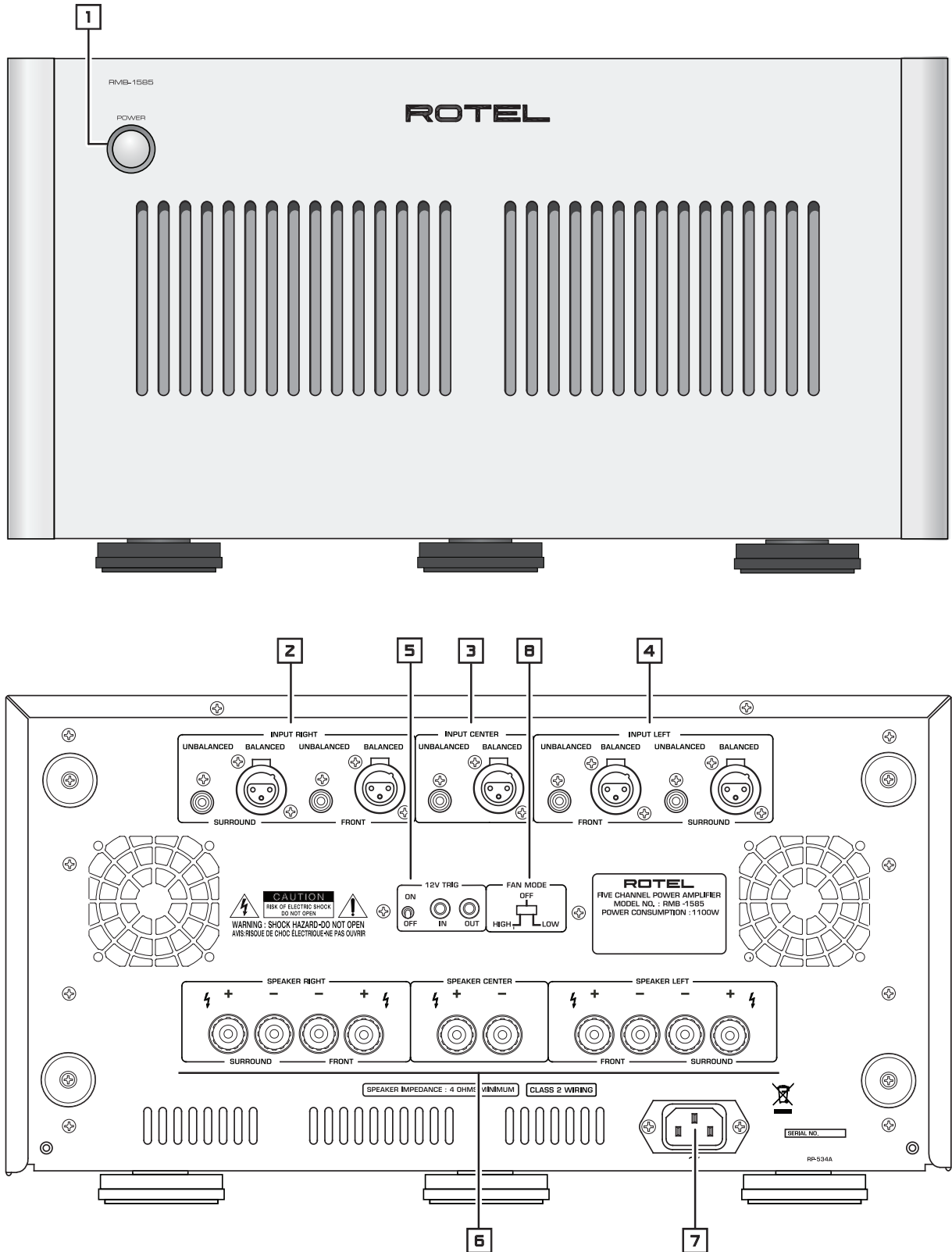

Figure 2: Analog Inputs and Speaker Output Connections

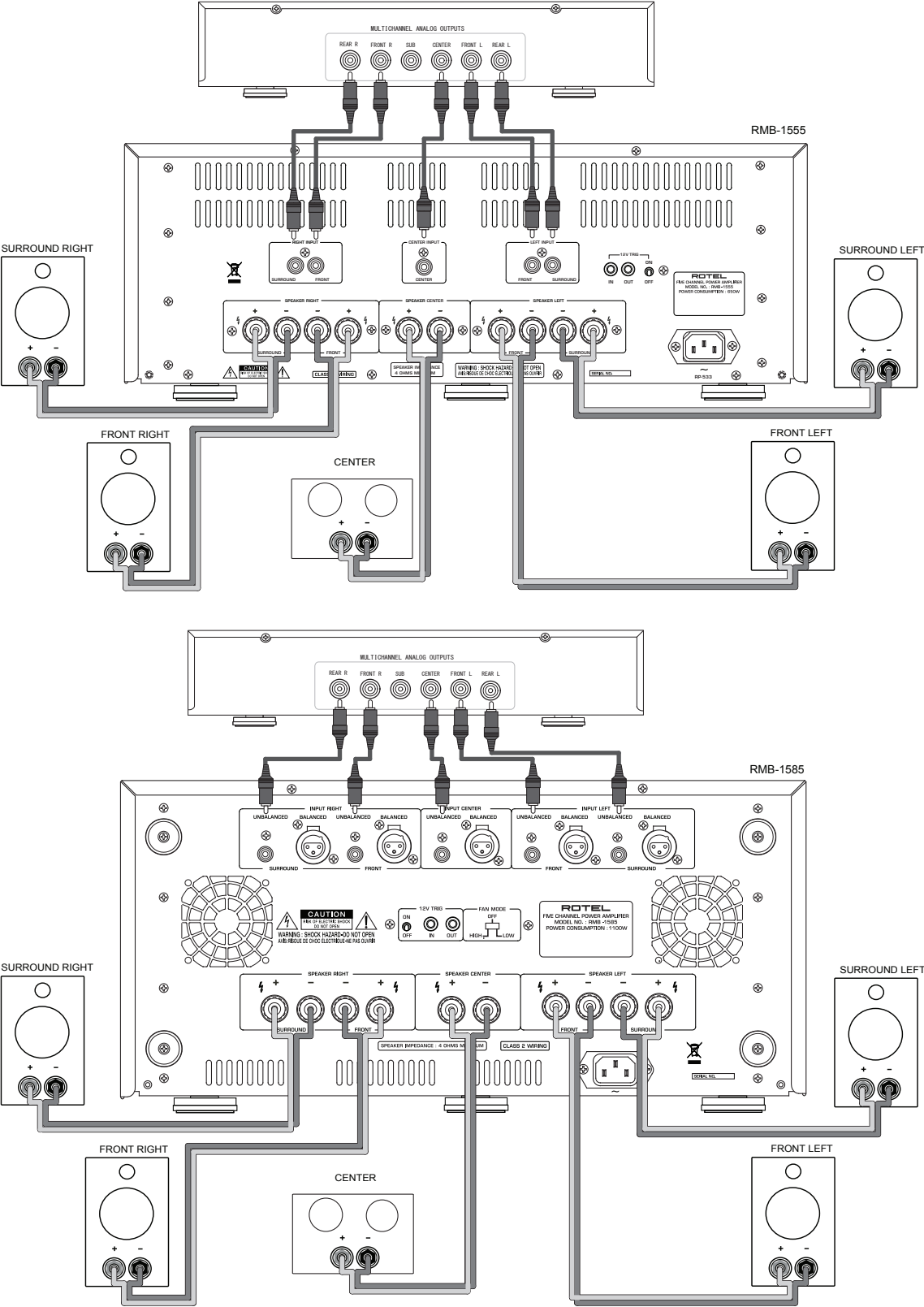
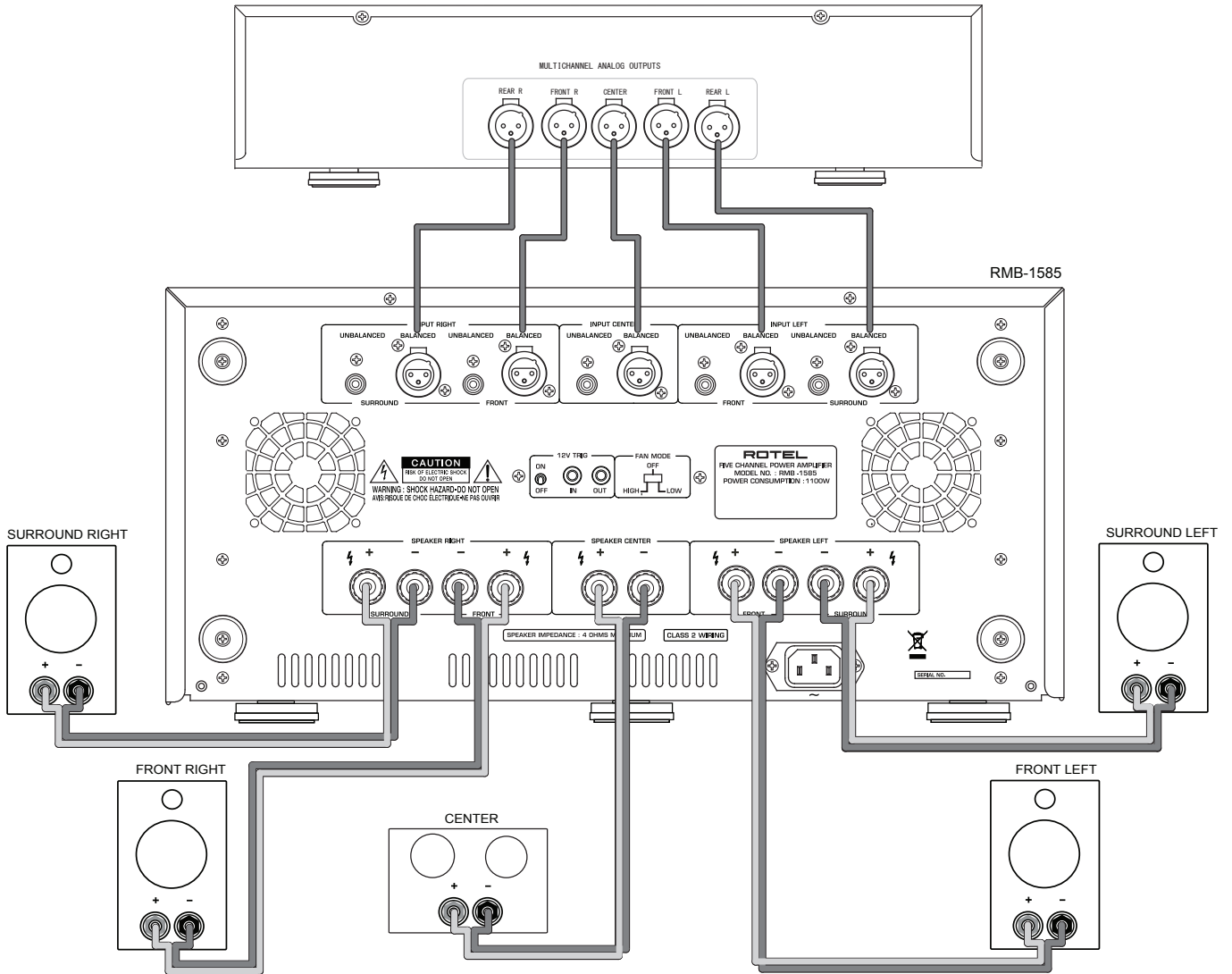

Figure 3: Balanced (XLR) Inputs



Important Notes

When making connections be sure to:

- ✓ Turn off **all** the components in the system **before** hooking up **any** components, including loudspeakers.
- ✓ Turn off **all** components in the system **before** changing **any** of the connections to the system.

It is also recommended that you:

- ✓ Turn the volume control of the amplifier all the way down **before** the amplifier is turned **on or off**.

Remarques importantes

Pendant les branchements, assurez-vous que :

- ✓ **Tous** les maillons sont éteints **avant** leur branchement, **quels qu'ils soient**, y compris les enceintes acoustiques.
- ✓ Éteignez **tous** les maillons **avant** de modifier **quoi que ce soit** au niveau de leurs branchements, quels qu'ils soient.

Il est également recommandé de :

- ✓ Toujours baissez le niveau sonore via le contrôle de volume, **avant d'allumer ou d'éteindre** l'amplificateur.

Wichtige Hinweise

Achten Sie beim Herstellen der Verbindungen auf Folgendes:

- ✓ Schalten Sie **alle** Komponenten im System ab, **bevor** Sie Geräte (einschließlich Lautsprecher) anschließen.
- ✓ Schalten Sie **alle** Komponenten im System ab, **bevor** Sie Anschlüsse im System verändern.

Ferner empfehlen wir, dass

- ✓ Sie die Lautstärke herunterdrehen, **bevor** Sie den Verstärker **ein-** oder **abschalten**.

Notas Importantes

Cuando realice las conexiones, asegúrese de que:

- ✓ Desactiva **todos** los componentes del equipo, cajas acústicas incluidas, **antes** de conectar **cualquier nuevo componente** en el mismo.
- ✓ Desactiva **todos** los componentes del equipo **antes** de cambiar **cualquier conexión del mismo**.

También le recomendamos que:

- ✓ Reduzca el nivel de volumen de su amplificador a cero **antes** de **activarlo o desactivarlo**.

Héél belangrijk

Bij het maken van de verbindingen:

- ✓ Zorg dat niet alleen de RMB-1555/1585, maar de **gehele** installatie uitstaat, als nog niet **alle** verbindingen gemaakt zijn.
- ✓ Zorg dat niet alleen de RMB-1555/1585, maar de **gehele** installatie ook uitstaat, **als** u verbindingen gaat **wijzigen**.

Wij raden u ook aan om

- ✓ de volumeregelaar van de (voor)versterker geheel dicht te draaien (volkomen linksom) **wanneer** u uw eindversterker **aan- of uitzet**.

Note importanti

Quando effettuate i collegamenti assicuratevi di:

- ✓ Spegnerne **tutti** i componenti del sistema **prima** di collegare **qualsiasi** componente, inclusi i diffusori.
- ✓ Spegnerne **tutti** i componenti del sistema **prima** di modificare **qualsiasi** connessione nel sistema.

Vi raccomandiamo inoltre di:

- ✓ Portare il volume a zero **prima** di **accendere o spegnere** l'amplificatore.

Viktigt

Tänk på följande när du gör anslutningar:

- ✓ Stäng av **alla** apparater i anläggningen **innan** du ansluter nya komponenter eller högtalare.
- ✓ Stäng av **alla** apparater i anläggningen **innan** du ändrar någon anslutning.

Du rekommenderas också:

- ✓ Vrida ner volymen på förförstärkaren helt och hållet **innan** förstärkaren slås **på eller av**.

Важные замечания









Перед подсоединением:

- ✓ Выключите **все** компоненты, включая колонки.
- ✓ Выключите **все** компоненты в вашей системе, прежде чем что-то в ней **менять**.

Рекомендуется также:

- ✓ Вывести громкость усилителя на **минимум**, перед тем как **включать или выключать** его.

Contents

Important Safety Instructions	2
Figure 1-1: RMB-1555 Controls and Connections	3
Figure 1-2: RMB-1585 Controls and Connections	4
Figure 2: Analog Inputs and Speaker Output Connections	5
Figure 3: Balanced (XLR) Inputs	6
Important Notes	7
About Rotel	8
A Word About Watts	8
Getting Started	8
A Few Precautions	9
Placement	9
AC Power and Control	9
AC Power Input 	9
Power Switch and Power Indicator 	9
Trigger ON/OFF Mode Selector 	9
12 Volt Trigger Input and Output 	9
Protection Circuitry 	9
Input Signal Connection   	10
Speaker Connection	10
Speaker Selection	10
Speaker Wire Selection	10
Polarity and Phasing	10
Speaker Connection 	10
Cooling Fans	10
Troubleshooting	11
Power Indicator Is Not Illuminated-	11
Fuse Replacement	11
No Sound	11
Pretection Indicator	11
Specifications	11

About Rotel

Our story began over 50 years ago. Over the decades, we have received hundreds of awards for our products and satisfied hundreds of thousands of people who take their entertainment seriously - like you!

Rotel was founded by a family whose passionate interest in music led them to manufacture high-fidelity components of uncompromising quality. Through the years, that passion has remained undiminished and the family goal of providing exceptional value for audiophiles and music lovers, regardless of their budget, is shared by all Rotel employees.

Rotel's engineers work as a close team, listening to, and fine tuning, each new product until it reaches their exacting musical standards. They are free to choose components from around the world in order to make that product the best they can. You are likely to find capacitors from the United Kingdom and Germany, semiconductors from Japan or the United States, while toroidal power transformers are manufactured in Rotel's own factory.

We all have concerns about our environment. And, as more and more electronics are produced and later discarded, it is especially important for a manufacturer to do all it can to engineer products that have a minimum negative impact on landfill sites and water tables.

At Rotel, we are proud to do our part. We have reduced the lead content in our electronics by using special ROHS solder, while our new Class D (not digital) amplifiers are up to five times more efficient than our legacy designs and still deliver power and performance. These products run cool, give minimum wasted energy, are good for the environment and give better sound too.

Finally, we have printed this brochure on recycled paper stock.

While we understand that these are small first steps, they are still important ones. And we continue to pursue new methods and materials for a cleaner and greener manufacturing process.

All of us at Rotel thank you for buying this product. We are sure it will bring you many years of enjoyment.

A Word About Watts

The RMB-1555 power output is quoted as 120 watts for each channel, and the RMB-1585 power output is quoted as 200 watts for each channel, when five channels are operating together at full power.

Rotel has chosen to specify the power output in this way because, in Rotel's experience, it gives the truest value of the receiver or amplifier's power capability.

When comparing specifications for different products, you should be aware that power output is often specified in other ways, so you may not be comparing like with like. For example, the power output may be quoted with only one channel operating, giving a higher maximum figure.

A loudspeaker's impedance rating indicates the electrical resistance or load it offers when connected to the amplifier, usually 8 ohms or 4 ohms. The lower the impedance, the more power the speaker will need. In effect, a 4 ohm speaker will require twice as much power as an 8 ohm speaker.

However, Rotel amplifiers are designed to work into any speaker impedance between 8 and 4 ohms, and with all the channels working up to their full power. Because the Rotel design is optimized for use with all channels operating together, Rotel is able to specify the true power output for both channels.

This can be important for your enjoyment, too. When watching movies, it's nice to have the amplifier able to reproduce full power into all the channels at the same time, especially in the case of a volcano exploding!

Getting Started

Thank you for purchasing the Rotel RMB-1555 or RMB-1585 Five Channel Power Amplifier. When used in a high-quality music or home theater system, your Rotel product will provide years of musical enjoyment.

The RMB-1555 and RMB-1585 are high-power amplifiers, providing the highest level of audio performance. Discrete output devices, a massive power supply, premium components, and Rotel's Balanced Design ensure superb sound quality. High current capability allow the RMB-1555 and RMB-1585 to drive the most demanding loudspeakers.

Be aware that the RMB-1555 and RMB-1585 are capable of high power levels, in excess of 120 watts and 200 watts respectively per channel. Make sure that your speakers can handle the power of the amplifier. If in doubt about your speakers, ask your local Rotel audio dealer for advice.

These amplifiers are straightforward in their installation and operation. If you have experience with other stereo power amplifiers, you shouldn't find anything perplexing. Simply plug in the associated components and enjoy.

A Few Precautions

WARNING: To avoid potential damage to your system, turn off ALL the components in the system when connecting or disconnecting the loudspeakers or any associated components. Do not turn the system components back on until you are sure all the connections are correct and secure. Pay particular attention to the speaker wires. There must be no loose strands that could contact the other speaker wires, or the chassis of the amplifier.

Please read this manual carefully. In addition to installation and operating instructions, it provides valuable information on various system configurations as well as general information that will help you get optimum performance from your system. Please contact your authorized Rotel dealer for answers to any questions you might have. In addition, all of us at Rotel welcome your questions and comments.

Save the shipping carton and all enclosed packing material for future use. Shipping or moving the amplifier in anything other than the original packing material may result in severe damage that is not covered by the warranty.

If included in the box please fill out and send in the owner's registration card. Also be sure to keep the original sales receipt. It is your best record of the date of purchase, which you will need in the event warranty service is required.

Placement

The RMB-1555 and RMB-1585 generate heat as part of its normal operation. The heat sinks and ventilation openings in the amplifier are designed to dissipate this heat. The ventilation slots in the top cover must be open. There should be 10 cm (4 inches) of clearance around the chassis, and reasonable airflow through the installation location, to prevent the amplifier from overheating.

Remember the weight of the amplifier when you select an installation location. Make sure that the shelf or cabinet can support it. We recommend installing the unit in furniture designed to house audio components. Such furniture is designed to reduce or suppress vibration which can adversely affect sound quality. Ask your authorized Rotel dealer for advice about component furniture and proper installation of audio components.

AC Power and Control

AC Power Input



Your amplifier is configured at the factory for the proper AC voltage in the country where you purchased it, either 120 volts or 230 volts. The AC line configuration is noted on a decal on the back panel.

NOTE: Should you move your amplifier to another country, it may be possible to reconfigure it for use on a different line voltage. Do not attempt to perform this conversion yourself. Opening the enclosure of the amplifier

exposes you to dangerous voltages. Consult a qualified service person or the Rotel factory service department for information.

NOTE: Some products are intended for sale in more than one country and as such are supplied with more than one AC cord. Please use only the cord appropriate for your country/region.

Because of its high power rating, the amplifier can draw considerable current. Therefore, it should be plugged directly into a wall outlet. The RMB-1555 and RMB-1585 must be plugged into a 3-pin polarized outlet. Do not use an extension cord. A heavy duty multi-tap power outlet strip may be used if it (and the wall outlet) is rated to handle the current demanded by the amplifier and all the other components connected to it.

Be sure the POWER SWITCH  on the front panel of the amplifier is turned off (in the "out" position). Then, connect the supplied power cord to the Power Connector  on the rear of the unit and the AC power outlet.

If you are going to be away from home for an extended period of time such as a month-long vacation, it is a sensible precaution to unplug your amplifier (as well as other audio and video components) while you are away.

Power Switch and Power Indicator

The power switch is located on the front panel of your amplifier. To turn the amplifier on, push the switch in. The ring around the switch will light up, indicating that the amplifier is turned on. To turn the amplifier off, push the button again and return it to the "out" position.

NOTE: Place the self adhesive ring over the light surrounding the Power switch if the blue light is too bright.

Trigger ON/OFF Mode Selector

The amplifier provides the option for manual or automatic power on/off operation. These modes are selectable using a toggle switch on the back panel.

With the switch in the +12V TRIGGER ON position, the amplifier is turned on automatically when a 12V trigger signal is present at the 3.5 mm Jack of TRIGGER IN on the rear panel. The amplifier will go into standby mode if the +12V signal is not present. The front panel POWER SWITCH overrides this function. It must be ON for the +12V trigger to work. Turning the switch OFF cuts power to the amplifier, regardless of whether or not a trigger signal is present.

12 Volt Trigger Input and Output

The jack labeled IN is for connecting the 3.5mm Plug/Cable carrying a +12 volt trigger signal to turn the amplifier on and off. To use this feature the toggle switch must be set to the ON position. This input accepts any control signal (AC or DC) ranging from 3 volts to 30 volts.

The jack labeled OUT is for connecting another 3.5mm plug/cable to provide a 12V trigger signal to other components. The 12V output signal is available whenever a +12 volt trigger signal is applied to the IN connector.

Protection Circuitry

The RMB-1555 and RMB-1585 feature thermal and over-current protection circuits that protect against potential damage in the event of extreme or faulty operating conditions. Unlike many designs, these protection circuits are independent of the audio signal and have no impact on sonic performance. Instead, the protection circuits monitors the temperature of the output devices and the current they are handling and shuts down the amplifier if operating conditions exceed safe limits.

Most likely, you will never see this protection circuitry in action. However, should a faulty condition arise, the amplifier will stop playing and the Power Indicator on the front panel will blink.

If this happens, turn the amplifier off, let it cool down for several minutes, and attempt to identify and correct the problem. When you turn the amplifier back on, the protection circuit will automatically reset and the Power Indicator should light up, indicating that the amplifier is turned on normal.

In most cases, the protection circuitry activates because of a fault condition such as shorted speaker wires, or inadequate ventilation leading to an overheating condition. In very rare cases, highly reactive or extremely low impedance speaker loads could cause the protection circuit to engage.

If the protection circuitry triggers repeatedly and you are unable to isolate and correct the faulty condition, contact your authorized Rotel dealer for assistance in troubleshooting.

Input Signal Connections 2 3 4

The RMB-1555 and RMB-1585 have conventional RCA type input connectors, the type found on nearly all audio equipment. The RMB-1585 also includes Balanced input connectors. Only one set of inputs should be connected. Never connected both Balanced and RCA inputs at the same time.

NOTE: To prevent loud potentially damaging noises, make sure the amplifier is turned off when you make any changes to the input signal configuration.

Select high quality audio interconnect cables. Connect each of the outputs from the preamplifier or signal processor to the corresponding input of the amplifier.

Speaker Connection

Speaker Selection

We recommend using loudspeakers with a nominal impedance of 4 ohms or higher with the RMB-1555 and RMB-1585. You should exercise some caution in driving multiple pairs of speakers in parallel configuration, because the effective impedance the amplifier sees is cut in half. For example, when driving two pair of 8 ohm speakers, the amplifier sees a 4 ohm load. When driving multiple speakers in parallel, it is recommended that you select speakers with a nominal impedance of 8 ohms or higher. Speaker impedance ratings are less than precise. In practice, very few loudspeakers will present any problems for the RMB-1555 or RMB-1585. See your authorized Rotel dealer if you have any questions.

Speaker Wire Selection

Use insulated two-conductor stranded wire to connect the amplifier to the speakers. The size and quality of the wire can have an audible effect on the performance of the system. Standard speaker wire will work, but can result in lower output or diminished bass response, particularly over longer distances. In general, heavier wire will improve the sound. For best performance, you may want to consider special high-quality speaker cables. Your authorized Rotel dealer can help in the selection of cables for your system.

Polarity and Phasing

The polarity – the positive/negative orientation of the connections – for every speaker and amplifier connection must be consistent so all the speakers will be in phase. If the polarity of one connection is reversed, bass output will

be very weak and stereo imaging degraded. All wire is marked so you can identify the two conductors. There may be ribs or a stripe on the insulation of one conductor. The wire may have clear insulation with different color conductors (copper and silver). There may be polarity indications printed on the insulation. Identify the positive and negative conductors and be consistent with every speaker and amplifier connection.

Speaker Connections 6

NOTE: The following text describes both binding post and plug-in connections. DO NOT use both connection methods in combination to connect multiple speakers.

Turn off all the components in the system before connecting the speakers. The RMB-1555 and RMB-1585 have two color coded binding posts, two for each channel. These connectors accept bare wire, connector lugs, or dual banana type connectors (except in the European Community countries where their use is not permitted).

Route the wire from the amplifier to the speakers. Give yourself enough slack so you can move the components to allow access to the speaker connectors.

If you are using dual banana plugs, connect them to the wires and then plug into the backs of the binding posts. The thumbscrews of the binding posts should be screwed in all the way (clockwise).

If you are using terminal lugs, connect them to the wires. If you are attaching bare wires directly to the binding posts, separate the wire conductors and strip the insulation from the end of each conductor. Be careful not to cut into the wire strands. Unscrew (turn counterclockwise) the binding post. Place the connector lug or wire around the binding post shaft. Turn the binding post clockwise to clamp the connector lug or wire firmly in place.

NOTE: Be sure there are no loose wire strands that could touch adjacent wires or connectors.

Cooling Fans

The Rotel RMB-1585 amplifier is equipped with dual cooling fans to help ventilate the internal components. The rear panel of the RMB-1585 includes a 3 position fan speed selection switch including **Fan Off**, **Fan Low Speed** and **Fan High Speed**. Please select the fan speed that best suits the installation and cooling requirements considering that higher speed fan will provide more cooling.

NOTE: The RMB-1585 produces significant power and associated heat - even with the cooling fans in use. Appropriate installation and ventilation is required to ensure proper operation.

Troubleshooting

Most difficulties in audio systems are the result of incorrect connections, or improper control settings. If you encounter problems, isolate the area of the difficulty, check the control settings, determine the cause of the fault and make the necessary changes. If you are unable to get sound from the amplifier, refer to the suggestions for the following conditions:

Power Indicator Is Not Illuminated

No main power to the amplifier. Check the front panel power switch. Make sure that it is set to the on position. Check AC power connections at the amplifier and the AC outlet.

Fuse Replacement

If another electrical device works when plugged into the power outlet, but the Power Indicator of the unit does not light when plugged into the same outlet and the Power Switch is pushed in, it indicates that the internal power fuse may have blown. If you believe this has happened, contact your authorized Rotel dealer to get the fuse replaced.

No Sound

If the amp is getting AC power, but is producing no sound, check the Protection indicator on the front panel. If it is lit, see below. If not, check all of your connections and control settings on associated components.

Protection Indicator

The front panel POWER indicator is blinking when the amplifier protection circuits have shut off the amplifier. Typically, this occurs only when the ventilation openings are blocked, when there is faulty speaker wiring, or after a period of extreme use. Turn off the system and wait for the amp to cool. Then push the front panel power switch in and out to reset the protection devices. If the problem is not corrected or reoccurs, there is a problem with the system or the amplifier itself.

Specifications

RMB-1555

Continuous Power Output <i>(20-20 kHz, < 0.03%, 8 ohms)</i>	120 watts/channel, 5 channels driven
Total Harmonic Distortion <i>(20Hz-20kHz, 8 ohms)</i>	< 0.03%
Intermodulation Distortion (60 Hz : 7 kHz, 4:1)	< 0.03%
Frequency Response (+0.5, -3dB)	10Hz - 100kHz
Damping Factor (20-20,000 Hz, 8 ohms)	180
Speaker Impedance	4 ohms minimum
Signal to Noise Ratio (IHF A network)	116 dB
Input Impedance/Sensitivity	12k Ohms/1.5 volt
Gain	26.5 dB
Power Requirements	
U.S. version	120 Volts, 60 Hz
European version	230 Volts, 50 Hz
Power Consumption	650 Watts
Dimensions	
Width x Height x Depth	431 x 188 x 454 mm 17 x 7 ¹ / ₂ x 17 ⁷ / ₈ ins.
Front Panel Height	4U / 176.8mm / 7 ins.
Weight (net)	21.8kg / 48.1 lbs.

RMB-1585

Continuous Power Output <i>(20-20 kHz, < 0.03%, 8 ohms)</i>	200 watts/channel, 5 channel driven
Total Harmonic Distortion <i>(20Hz-20kHz, 8 ohms)</i>	< 0.03%
Intermodulation Distortion (60 Hz : 7 kHz, 4:1)	< 0.03%
Frequency Response (+0.5, -3dB)	10Hz - 100kHz
Damping Factor (20-20,000 Hz, 8 ohms)	260
Speaker Impedance	4 ohms minimum
Signal to Noise Ratio (IHF A network)	116 dB
Input Impedance/Sensitivity	
Unbalanced	12k Ohms/1.9 volt
Balanced	100k Ohms/3.8 volt
Gain	26.5 dB
Power Requirements	
U.S. version	120 Volts, 60 Hz
European version	230 Volts, 50 Hz
Power Consumption	1100 Watts
Dimensions	
Width x Height x Depth	431 x 237 x 454 mm 17 x 9 ³ / ₈ x 17 ⁷ / ₈ ins.
Front Panel Height	5U / 221mm / 8 ³ / ₄ ins.
Weight (net)	36kg / 79.3 lbs.

All specifications are accurate at the time of printing.

Rotel reserves the right to make improvements without notice.

Rotel and the Rotel HiFi logo are registered trademarks of The Rotel Co, Ltd., Tokyo, Japan.

重要安全说明

警告：机内无客户可以维修的部件。请合格维修人员维修。

警告：为减少火灾或触电的危险，不要将本产品置于潮湿环境中或水中。不要将本产品置于滴水或溅水环境中。不要将含有液体的物件（例如花瓶）放在本产品上。不要让异物进入本产品外壳内。如果本产品进入潮湿环境中，或异物进入本产品内，立即从墙上拔掉电源线。将本产品送交合格维修人员检查或进行必要的维修。

连接或操作之前，请阅读所有说明。

请保留本手册，以便阅读这些安全说明。

请留意这些说明和产品上的所有警告或安全信息。请遵从操作说明。

只能用于布或真空吸尘器清洁。

不要在接近水的地方使用本产品。

本产品周围最少应有10cm或4in.的间隙。

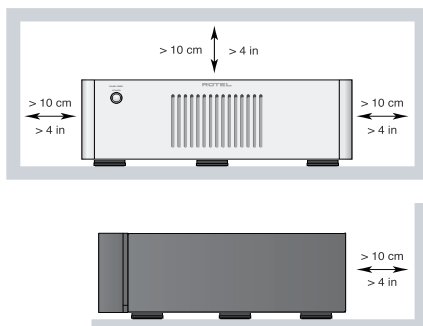

不要将本产品置于床上、沙发、垫子或类似的物体上，以防堵塞通风口。如果将本装置放在书柜或橱柜上，柜上应有通风口，以便于产品的散热。

请将本产品远离辐射、热源、火炉或其它发热器具。

警告：后面板上的电源线接头是主电源断开装置。应该将本机放在可拔插电源线接头的开放的地方。

只能将本产品连接到后面板指定的型号和电压的电源上。（美国：120V/60Hz，欧洲：230V/50Hz，中国：220V/50Hz）

只能用本产品提供的电源线或严格等同的电源线将本产品连接到电源插座上。不得更改随本产品提供的电源线。两极插头有两个插刀，其中一个插刀比另一个宽。接地插头有两个插刀和第三个接地插刀。这些都是为了您的安全。不得违反接地和两极安全规定。如果随本产品提供的插头与您的插座不匹配，请咨询电工更换陈旧的插座。不要使用延长线。

电源电缆的主插头是本产品的断电装置。要将本产品从电源完全断开，应从主（交流）插座上拔下电源电缆的主插头。拔掉电源线后，待机指示灯熄灭。断路装置保持随时可操作状态。

不要使用变形的、收缩的、弯折的或损坏的，电源线，不要将电源线置于热源附近。请特别留意插头处和本装置后面的电源线。

雷暴天气中或本装置长时间不使用时，应将电源线从墙上插头中拔出。

应当将本设备连接到带保护接地连接的电源插座中。

只能使用制造商指定的附件。

只能使用洛得推荐的机架、立架或支架。在支架或机架上移动本装置时，请小心避免翻侧。



使用2类电线连接音箱，以确保正确的安装及将触电风险减至最低。

在下列情况下，立即停止使用本装置，并请合格维修机构检测和维修：

- 电源线或插头损坏
- 异物或液体进入进装置中
- 本装置遭受雨淋
- 本装置显示不正确操作的迹象
- 本装置跌落或以任何方式被损坏

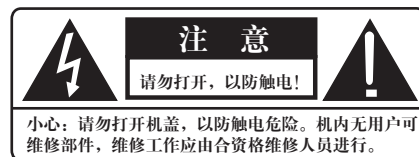

适用于美国、加拿大、或其它核准使用的地方。

小心：避免触电，请将宽片插头对准宽口插座。完全插入。

注意：为避免触电，请将插头最大（长）的那片（头）插入插座相应端口并插到底。



本标记用于提醒用户，本产品内有未绝缘的危险电压，可能引致触电风险。



标记提醒用户遵从本手册及随附文件中的操作和维护（维修）指引。



洛得产品符合电气和电子设备限制有害物质（RoHS）以及处理废旧电气和电子设备（WEEE）的国际指令。带叉形符号的轮式垃圾箱标志合乎规定，且该产品应根据这些指令以适当的方法进行回收或处理。

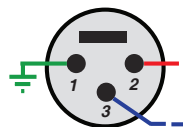

引脚分配
平衡音频（3个平衡极点）：
脚1：地极/屏蔽
脚2：同相/+正极/热
脚3：异相/-负极/冷



图1-1: RMB-1555 控制与连接



图1-2: RMB-1585 控制与连接



图 2: 模拟输入与音箱输出连接

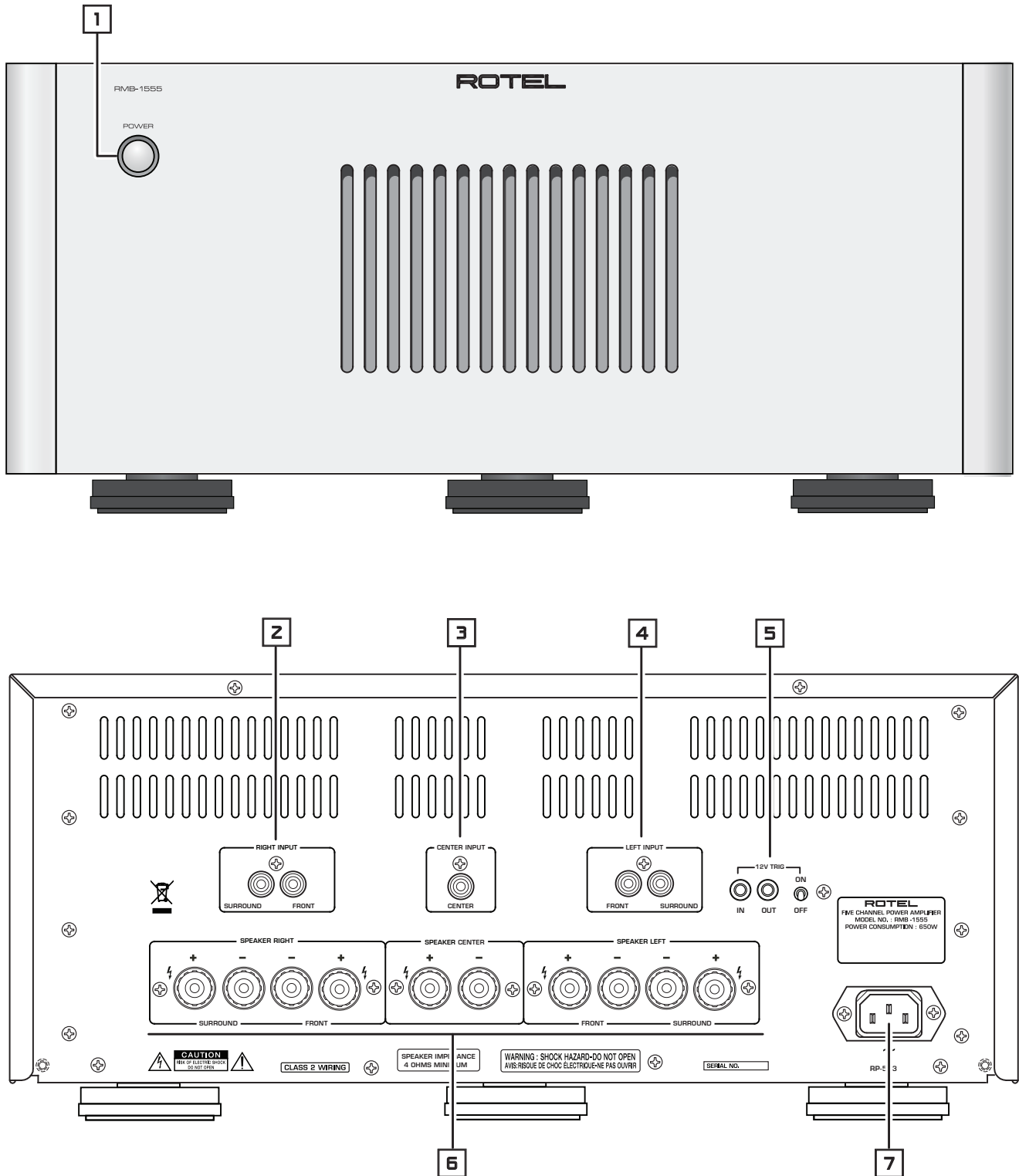

图3: 平衡(XLR)输入

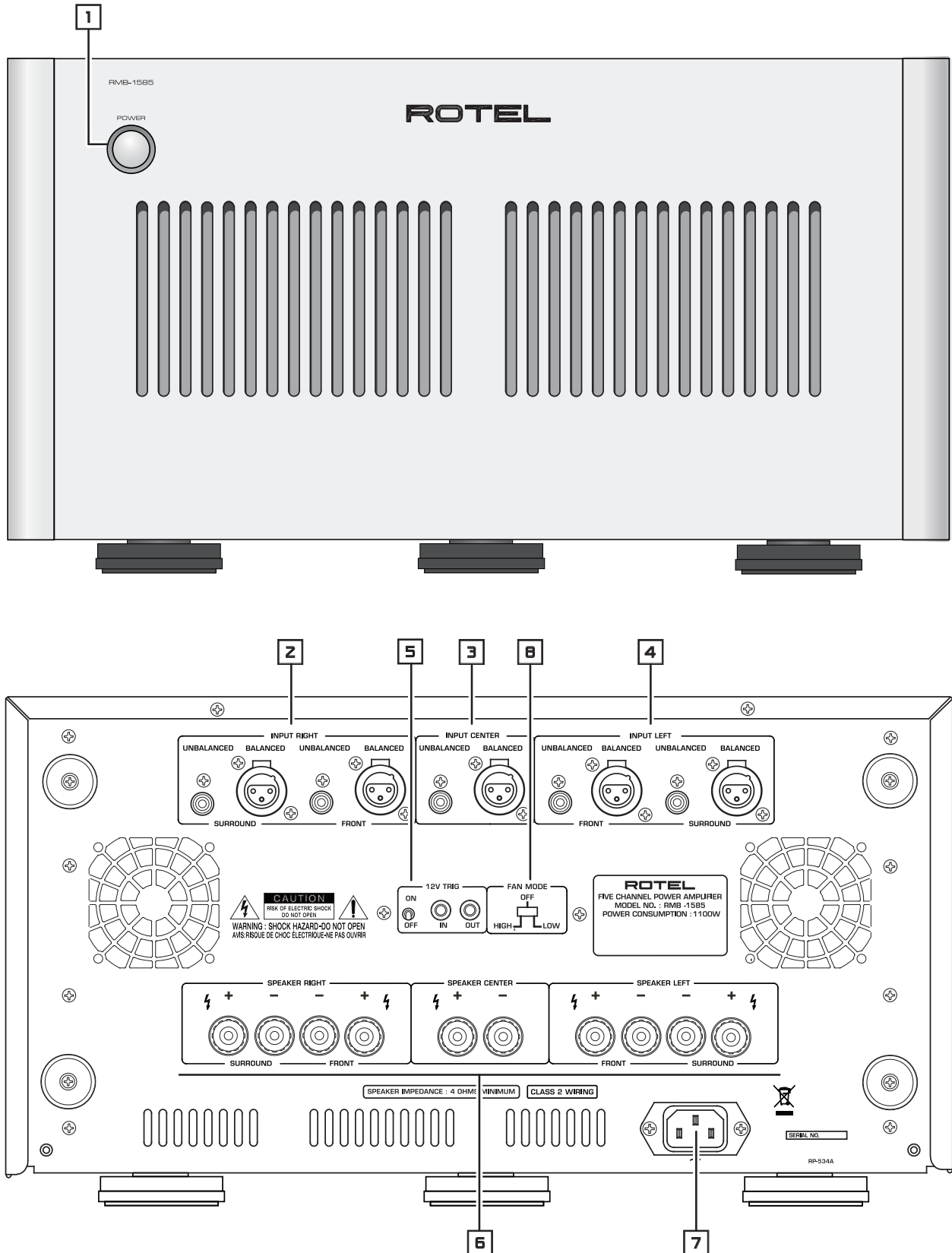

重要注意事项

进行连接时，请确保：

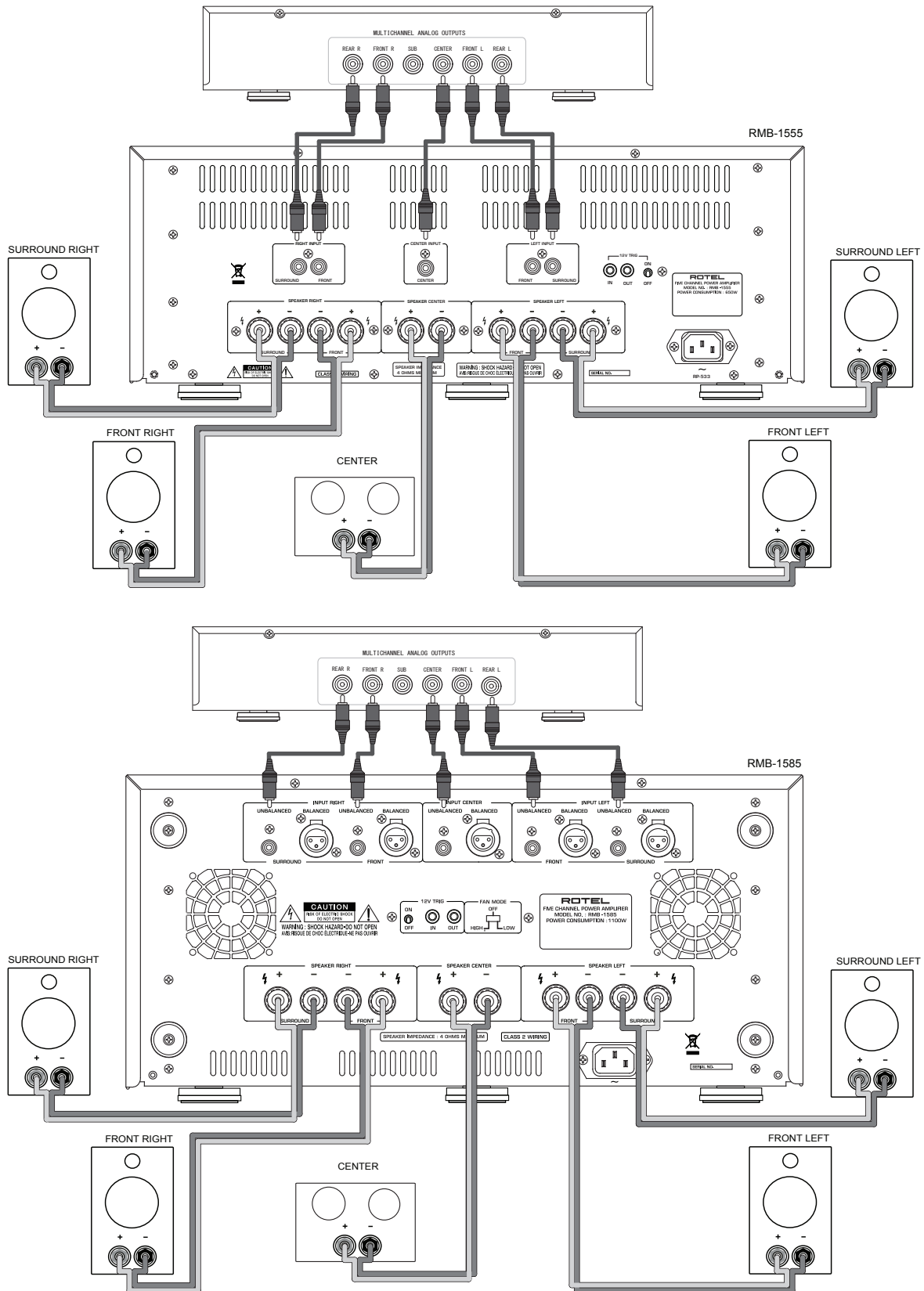
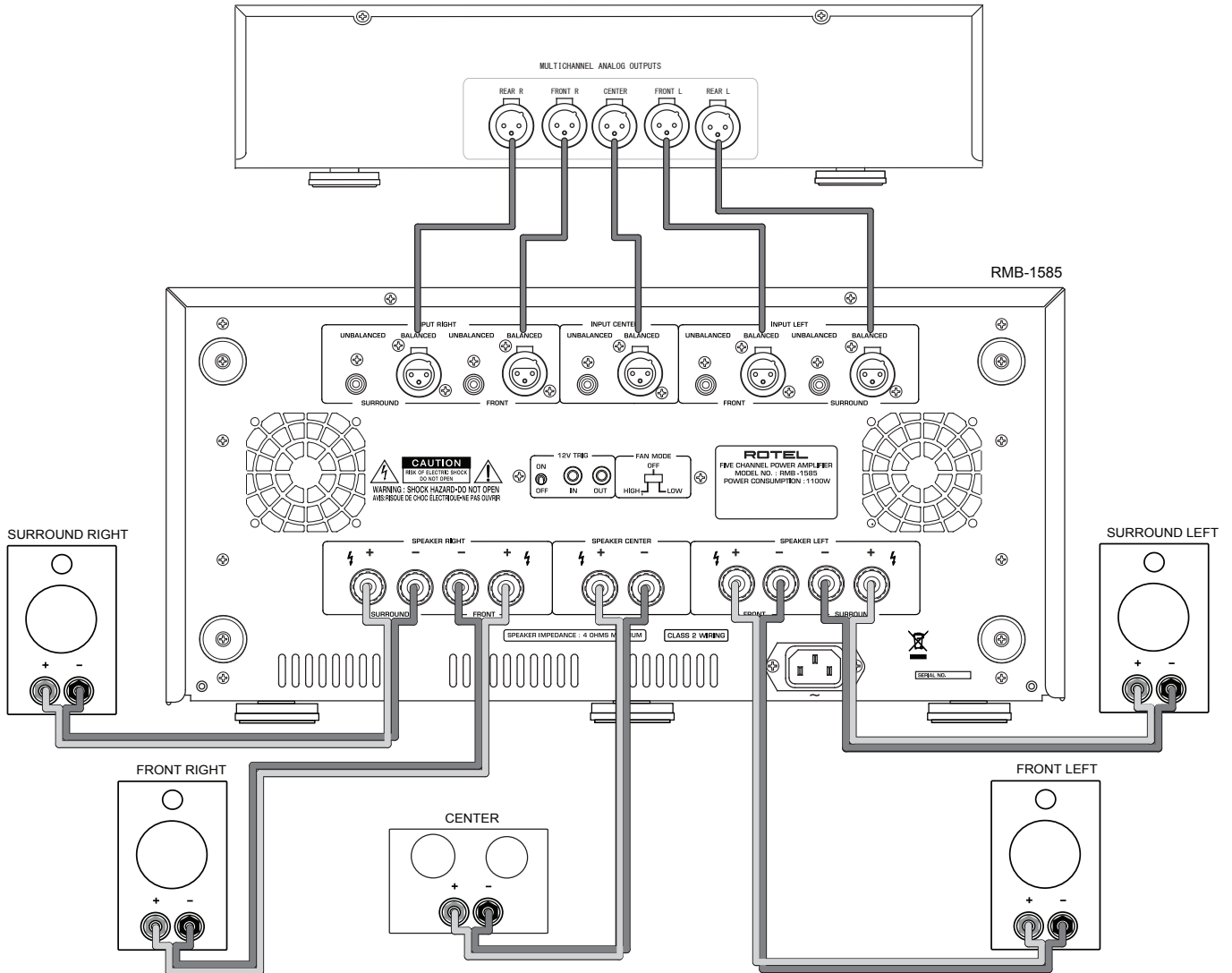
- ✓ 连接任何设备（包括音箱）之前，应关闭系统中所有设备的电源。
- ✓ 改变系统的任何连接之前，应关闭系统中所有设备的电源。

我们还建议您：

- ✓ 打开或关闭放大器之前，将放大器的音量控制调到最低。

目录

重要安全说明	12
图1-1: RMB-1555 控制与连接	13
图1-2: RMB-1585 控制与连接	14
图2: 模拟输入与音箱输出连接	15
图3: 平衡(XLR)输入	16
重要注意事项	16
关于洛得	17
功率简介	17
开始使用	17
几点注意事项	17
放置	18
交流电源和控制	18
交流电源输入 	18
电源开关和电源指示灯 	18
触发模式选择开关 	18
12V触发输入和输出 	18
保护电路 	18
输入信号连接   	18
音箱输出	18
音箱选择	18
音箱线选择	18
极性和相位	18
音箱连接 	19
冷却风扇	19
故障排除	19
电源指示灯不亮	19
更换保险丝	19
没有声音	19
保护指示灯	19
技术参数	19

关于洛得

洛得已有超过50年的历史。几十年来，我们的产品已赢得数百次奖项，满足了无数对娱乐有着严肃态度的人士——比如您。

洛得是一个家族公司，他们对音乐的激情让他们致力于制造高品质的高保真音响设备。多年以来，这种激情丝毫未减，而为不同预算的高保真音响发烧友和音乐爱好者提供超值产品的目标，是洛得所有员工的共同追求。

洛得的工程师紧密协作，认真倾听并精确调谐每个新产品，直到其符合苛刻的音乐标准。他们从世界各地挑选部件，以令其产品尽善尽美。您可能会发现英国和德国生产的电容器、日本和美国产的半导体，以及洛得自己工厂制造的环形功率变压器。

我们十分关注环境。随着越来越多的电子产品出现，随后被废弃，制造商竭尽所能设计对垃圾填埋场和地下水带来最低负面影响的产品就显得尤为重要。

在洛得，我们做到了这一点，我们对此深感自豪。通过使用特殊的ROHS焊料，我们降低了电子产品中的铅含量，同时，我们最新的D类（非数码）放大器的效率是传统设计的五倍之多，同时仍可提供大功率和很高的性能。这些产品运行时温度低，能源浪费少，不损害环境，并带来更好的音质。

最后，我们用可回收的纸张印刷手册。

虽然我们知道这些事情微不足道，但它们对环保仍然非常重要。我们会继续寻找新的方法和材料，开发更加清洁、更加环保的制造工艺。

洛得的全体同仁感谢您购买本产品。我们深信，本产品将为您带来数年的美妙享受。

功率简介

五个声道均以最大功率运作时，RMB-1555的额定功率输出为每声道功率120W，RMB-1585的额定功率输出为每声道功率200W。

洛得采用这种方式标注功率输出的原因是，在洛得的实践经验中，它能传输给接收器或功放器最真实的数值。

与其它产品的技术参数相比，您会发现它们通常以其它方式标注功率输出，所以您不能以这种方式进行比较。例如，它们提供的功率输出可能只是一个声道工作时的功率输出，从而给出一个更高的最大数值。

音箱的额定阻抗表示它们连接到放大器时提供的电阻或负荷，通常为8Ω或4Ω。阻抗越低，音箱需要的功率更高。实际上，一只阻抗为4Ω的音箱所需要的功率为8Ω音箱的两倍。

但是，洛得放大器的设计可使用阻抗介于8Ω和4Ω之间的任何音箱，所有声道均可以最大功率运作。基于对所有声道同时工作进行了设计优化，洛得能够对所有声道标定真实的功率输出。

这对于您的娱乐享受很重要。当您看电影，尤其是观看火山爆发等场景时，拥有一套能同时驱动所有声道的高功率放大器，绝对会是一种美妙的享受。

开始使用

感谢您购买洛得RMB-1555或RMB-1585多声道后置放大器。配合高质量的音音乐系统使用，洛得产品可为您提供多年的音乐享受。

RMB-1555和RMB-1585是高功率放大器，提供最高水平的音质表现。独立的输出装置、大功率电源、优质的元件以及洛得的平衡设计理念共同确保上乘的音质。大电流输出能力可使RMB-1555和RMB-1585轻松驱动要求最为严格的音箱。

RMB-1555和RMB-1585的输出功率非常大，每声道功率分别均超过130W和200W。请确保您的音箱可以承受RMB-1555或RMB-1585的功率。如对您音箱存在疑问，请咨询当地洛得授权经销商。

RMB-1555和RMB-1585的安装和操作都非常简单。如果您有使用其它后置放大器的经验，您会发现一切均易如反掌。您只需要把相关组件连接起来即可开始享受完美音质。

几点注意事项

警告：要避免可能造成系统的损坏，进行连接或断开音箱或相关组件之前应关闭所有系统组件。确保所有连接均正确和安全后再开启系统组件。请特别注意音箱线。确保没有松开的线束与其它音箱的电线或放大器的机架接触。

请仔细阅读本手册。除了基本安装和操作说明外，本手册还提供了关于RMB-1555和RMB-1585系统设置的资料以及一般信息，帮助您优化系统的性能。如果您遇到任何问题，请联络洛得授权经销商。另外，洛得全体同仁欢迎您提出问题或建议。

请保存好包装箱和包装材料，以备日后使用。使用非原包装材料运输或移动放大器可能会严重损坏放大器。

包装中若有用户注册卡，请填写并寄回给我们。另请保留原始销售收据。它是购买日期的最佳记录，您日后需要保修时会用到它。

放置

RMB-1555和RMB-1585在正常工作过程中会产生热量。放大器上的散热器和通风口用于排出热量。上盖的通风口应该打开。为防止放大器过热，机身周围应有10厘米（4英寸）的间隙，且安装位置应有适度的气流通过。

选择安装地点时应考虑放大器的重量。请确保机架或机柜能够承载本设备的重量。本公司建议将放大器安装在为安装音响器材设计的家具内。这些家具可以降低或减少对声音质量产生负面影响的振动。设备家具和音频设备的正确安装方法，请咨询授权洛得经销商。

交流电源和控制

交流电源输入 ①

您的放大器在出厂时已设置为您购买本产品所在国家的交流电压（美国：120V/60Hz，欧洲：230V/50Hz，中国：220V/50Hz）。交流电压配置标注在背面板的标签上。

注意：如果将放大器带到另一个国家，可能需要重新设置以使用不同的电压。不要试图自行进行转换。打开放大器的外壳会有触电危险。请咨询合格维修人员或洛得工厂服务部门寻求帮助。

注意：有些产品将出售于多个国家，因此提供了多条AC电源线，请选择一条适用于您的国家/地区的电源线。

由于RMB-1555和RMB-1585的高电源功率，它会产生大量电流。因此，应该将本设备直接插到墙上的三极插座。不要使用延长线。如果大功率多插孔插线板（和墙插座）可以承受RMB-1555或RMB-1585和所有插到上面的其它器材，则可以使用多插孔插线板。

请确保放大器前面板上的电源开关 ① 已关闭（位于弹出的位置）。然后，将电源线连接到放大器背面的电源连接器 ② 及交流电源插座上。

如果您将要离家较长时间，例如一个月，离开前请务必拔下放大器（和其它音频视频设备）的电源插头。

电源开关和电源指示灯 ①

电源开关位于放大器的前面板上。要打开放大器的电源，将本开关接入。电源打开时，电源按键周围的指示灯会变亮。要关闭放大器，再次按下按键将其复位。

注意：如果蓝色光线太亮，请在电源按键周围贴上调光圈。

触发模式选择开关 ⑤

本放大器提供手动或自动开/关机操作的选择。该模式可以通过后面板上的开关进行选择。

本开关置于+12V TRIGGER（12V触发信号）ON（开）的位置时，如果向后面板标注TRIGGER IN（触发信号输入）的3.5毫米插孔施加12V触发信号，则放大器会自动打开。失去该12V触发信号，放大器则会进入无信号的待机状态。要让12V触发开关工作，前面板上的POWER SWITCH（电源开关）应位于ON（开）的位置。将开关置于OFF（关）的位置将切断放大器电源，无论触发信号是否存在。

12V触发输入和输出 ⑤

标记为 IN 的插孔用于连接带有+12V触发开关信号的3.5毫米插头/电缆。要使用本功能，触发开关应设置到 ON（开）的位置。本接入接口接受3V至30V的任何控制信号（交流或直流）。

标记为 OUT 的插孔用于连接为其它设备提供12V触发信号的3.5毫米插头/电缆。向IN接口施加+12V触发信号时，该接口提供12V输出信号。

保护电路 ①

在过度或错误操作的情况下，热保护电路和过流保护功能会保护放大器免受可能的损坏。不同于许多设计，RMB-1555和RMB-1585的保护电路独立于音频信号，对音质表现没有影响。相反，保护电路监控输出装置的温度，如果温度超出安全限度，将关闭放大器。

如果出现故障情况，放大器将停止运作，前面板上的电源指示灯将会闪烁。

发生这种情况时，关闭放大器电源，让其冷却几分钟，并尝试确定及解决该问题。重新打开放大器时，保护电路自动重置，电源指示灯将会点亮，表明放大器正常启动。

大多数情况下，保护电路由于错误情况例如音箱电线短路或通风不畅引起温度过高而激活。在极罕见的情况下，高度灵敏的或太低的音箱阻抗负载可能造成保护电路介入。

如果保护电路重复触发，而您无法确定和解决故障，请联络授权洛得经销商寻求帮助，解决问题。

输入信号连接 ② ③ ④

RMB-1555和RMB-1585设有几乎所有音频设备上都有的非平衡(RCA)型连接。RMB-1585还配有平衡(XLR)型输入连接。请只选用一种连接方式，不可同时使用RCA和XLR连接。

注意：要避免高噪声对您和音箱的影响，进行任何信号连接之前，应关闭所有系统组件。

请选用高质量的音频互连电缆。将前置放大器或信号处理器的每个输出连接到RMB-1555和RMB-1585相应的输入连接。

音箱输出

音箱选择

我们建议使用标称阻抗为4Ω或以上的音箱。驱动多对并行配置的音箱时，你应该注意某些事项，因为放大器的有效阻抗被减半。例如，驱动两对8Ω的音箱时，放大器的负载为4Ω。驱动多对并联连接的音箱时，建议选用额定阻抗为8Ω以上的音箱。音箱额定阻抗要比实际阻抗低。实际上，极少有音箱在与RMB-1555或RMB-1585一同使用时会出现问题。如果有任何疑问，请咨询授权洛得经销商。

音箱线选择

使用绝缘的双导线连接放大器和音箱。电线的大小和质量可能会对系统的性能产生明显的效果。标准的音箱线也能用，但是可能会导致输出降低或减少低音响应，尤其是在距离较远的情况下。通常，重量更重的线会提升音质。为得到最佳效果，您可能需要考虑特别的高质量音箱电缆。洛得授权经销商可以帮助您为您的系统选择合适的电缆。

极性和相位

每个音箱的极性，即连接的正/负(+/-)方向和放大器连接应保持一致，以确保所有音箱在相同相位上。如果一个连接接反，低音输出会非

常微弱，立体声效果会降低。所有音箱线上均有标记，您可以区别两根导线。在一股导线的绝缘套上可能有小标签。电线绝缘套内的导线可能有不同颜色（铜或银）。绝缘上可能印有极性标记。找到正负导线，并确保每个音箱和放大器的连接一致。

音箱连接

注意：以下内容说明了接线柱和插入式连接的方法。不要混合使用两种接线方式连接多个音箱。

连接音箱前请关闭系统中所有设备的电源。放大器的后板上有以颜色区分的音箱接线柱。这些接线柱可以连接裸线、接线插片或双“香蕉”型接头（欧盟国家不允许使用）。

将电缆从放大器连接到音箱。要留有足够的余地，以便可以移动设备以连接到扬声器接线柱上。

如果您使用香蕉型插头，先接到线上然后插到音箱接线柱后面。应拧紧音箱接线柱上的套环（顺时针）。

如果使用接线插片，将其连接到电线上。如果您直接将裸线连接到音箱接线柱上，请分开电线的导线，并自每根导线的端头将绝缘剥去。请小心不要将导线切断。将音箱接线柱的套环拧开（逆时针方向）。将接线片或导线绕在接线柱轴上，顺时针拧紧套环，固定接线插片或线头。

注意：请确保没有松开的线束与邻近的电线或导线接触。

冷却风扇

洛得RMB-1585配有两个冷却风扇以便内部零件通风散热，在其后面板上还有一个风扇转速的选择开关，分别是关掉（**Fan off**），低速（**Fan Low Speed**），高速（**Fan High Speed**）。请选择符合机器安装和散热要求的风扇转速，须注意风扇转速越高，冷却能力越强。

注意：即使配有冷却风扇，但RMB-1585在运行时仍会产生相当大的功率和热量，请正确安装本机器并注意通风良好以确保机器的正常运行。

故障排除

音频系统的多数故障是由于错误连接或控制设置不正确所致。如果您遇到问题，请屏蔽有问题的区域，检查控制器设置，确定故障原因并进行必要的修正。如果放大器仍然没有声音，请参考以下状况的建议：

电源指示灯不亮

没有连接电源，请检查放大器前面板的电源开关，确保开关处于开（ON）的位置。检查放大器和AC插座的AC电源连接。

更换保险丝

如果其它电气设备插到该插座时可正常工作，但放大器插到同一插座且电源开关打开时电源指示灯不亮，表明内置保险丝可能已烧断。如果您确信发生这种情况，请联络授权洛得经销商更换保险丝。

没有声音

如果放大器已连接电源，但仍然没有声音，请检查前面板上的保护指示灯。如果灯在闪烁，请参阅下文。如果灯不亮，请检查关联设备的所有连接和控制器设置。

保护指示灯

放大器的保护电路关闭放大器后，前面板的电源指示会闪烁。通常，在通风口堵塞、音箱连接错误或长时间过度使用的情况下才会出现这种情况。

关闭系统，等待放大器冷却。然后按下并按出前面板上的电源开关重置保护装置。如果问题仍未得到解决或再次出现，则系统或放大器有故障。

技术参数

RMB-1555

连续功率输出	120 W/声道, 驱动5声道
(20-20 kHz, < 0.03%, 8Ω)	
总谐波失真	< 0.03%
(20Hz-20kHz, 8Ω)	
互调失真 (60 Hz : 7 kHz, 4:1)	< 0.03%
频率响应 (+0.5, -3dB)	10Hz - 100kHz
阻尼因数 (20-20,000 Hz, 8 Ω)	180
音箱阻抗	最低4Ω
信噪比 (IHF A网络)	116 dB
输入阻抗/灵敏度	12kΩ/1.5V
增益	26.5 dB
电源要求	
美国	120V, 60 Hz
欧洲	230V, 50 Hz
中国	220V, 50Hz
功率消耗	650 W
尺寸	
(宽×高×深)	431 x 188 x 454 mm
	17 x 7 ¹ / ₂ x 17 ⁷ / ₈ ins.
前面板高度	4U / 176.8mm / 7 ins.
重量 (净重)	21.8kg / 48.1 lbs.

RMB-1585

连续功率输出	200 W/声道, 驱动5声道
(20-20 kHz, < 0.03%, 8Ω)	
总谐波失真	< 0.03%
(20Hz-20kHz, 8Ω)	
互调失真 (60 Hz : 7 kHz, 4:1)	< 0.03%
频率响应 (+0.5, -3dB)	10Hz - 100kHz
阻尼因数 (20-20,000 Hz, 8 Ω)	260
音箱阻抗	最低4Ω
信噪比 (IHF A网络)	116 dB
输入阻抗/灵敏度	
非平衡 (RCA)	12kΩ/1.9V
平衡 (XLR)	100k Ω/3.8V
增益	26.5 dB
电源要求	
美国	120V, 60 Hz
欧洲	230V, 50 Hz
中国	220V, 50Hz
功率消耗	1100 W
尺寸	
(宽×高×深)	431 x 237 x 454 mm
	17 x 9 ³ / ₈ x 17 ⁷ / ₈ ins.
前面板高度	5U / 221mm / 8 ³ / ₄ ins.
重量 (净重)	36kg / 79.3 lbs.

本手册印刷时所有参数均属精确。

洛得保留修改的权利，恕不另行通知。

Rotel 和 the Rotel Hi-Fi标记均属日本东京洛得有限公司的注册商标。



ROTEL®

中国洛得

珠海保税区洛得电子有限公司

地址：中国广东省珠海市珠海保税区第27号区域

电话：0756-8936088

传真：0756-8936222

The Rotel Co. Ltd.

日本洛得

Tachikawa Bldg. 1F.,

2-11-4, Nakane, Meguro-ku,

Tokyo, 152-0031

Japan

Rotel of America

美国洛得

54 Concord Street

North Reading, MA 01864-2699

USA

电话：+1 978-664-3820

传真：+1 978-664-4109

Rotel Europe

欧洲洛得

Dale Road

Worthing, West Sussex BN11 2BH

England

电话：+ 44 (0)1903 221 761

传真：+44 (0)1903 221 525

Rotel Deutschland

德国洛得

Vertrieb: B&W Group Germany GmbH

Kleine Heide 12

D-33790 Halle/Westf., Deutschland

电话：05201 / 87170

传真：05201 / 73370

电邮：info@bwgroup.de

www.rotel.com