

# owner's manual

PHOTO: RPM-10MKII



Quality. Uncompromised.

# ROTEL®



# ENGLISH

MW/LW/FM STEREO PORTABLE MICRO SYSTEM RPM-10  
MW/SW/FM STEREO PORTABLE MICRO SYSTEM RPM-10S

## INTRODUCTION

We at Rotel want to thank you for purchasing our audio product.

Rotel audio products are designed to use the latest electronic technology, and they incorporate our long experience as a specialist manufacturer of audio equipment. We are confident that you will find satisfaction in the high quality sound and top performance, and that you will find pleasure in the functional beauty achieved through human-engineering concept. Before starting operation, please read this instruction manual thoroughly and acquaint yourself with the proper mode of using the unit and all its connections.

We hope you will enjoy top-notch performance for many years to come.

## BEFORE ENJOYMENT

Follow the instructions below for maximum safety:

### 1. Installation

Be sure to place the unit in a level and flat place where it is free from humidity, vibration, high temperature and not exposed to direct sunlight.

### 2. Ventilate the unit well

Never block any ventilation holes at the top and bottom of the unit. Be sure also to provide ample ventilation space around the unit. Poor ventilation may result in damage due to excessive heat.

### 3. Do not open the cabinet

In order to avoid electric shock or damage to the component, never open the cabinet. If a foreign object falls inside the unit by mistake, turn the power off, disconnect the wall plug, and consult a qualified electrician or your dealer.

### 4. If the unit gets wet

If the unit should get wet, immediately disconnect the AC cord, and consult your dealer or a qualified electrician.

### 5. Cleaning and maintenance

Do not use chemicals such as benzene or thinners on the front panel. Always use a soft, dry cloth to clean the unit.

### 6. Owner's manual

Keep the owner's manual near the unit, and record the serial number (found on the rear panel) on the cover.

## EXCLUSIVE NOTE FOR U.K.

### Connecting Bulgin Plug

If your unit comes with a 2-core cable without a plug, make certain live and neutral leads are connected to the proper terminals. Check that the terminals are screwed down firmly and no loose strands of wire are present.

**IMPORTANT:** The wires in this mains lead are coloured in accordance with the following code:

BLUE: NEUTRAL  
BROWN: LIVE

As the colours of the wires in the mains lead of this apparatus may not correspond with the coloured markings identifying the terminals in your plug proceed as follows. The wire which is coloured BLUE must be connected to the terminal which is marked with the letter N or coloured BLUE or BLACK. The wire which is coloured BROWN must be connected to the terminal which is marked with the letter L or coloured BROWN or RED.

## POWER SOURCES

When plugging in or unplugging the RPM-10(S), or when inserting or removing the batteries, first make sure the power switch on the main unit is turned off.

### • Household AC

Connect the supplied AC power cord to AC IN socket on the rear of the main unit, and then to a wall outlet. When the cord is plugged into the AC IN socket, the internal batteries (if inserted) are automatically disconnected.

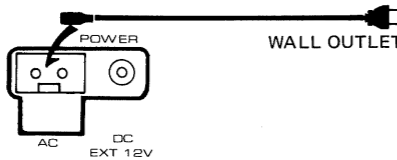

### • Batteries

Open the battery compartment lid on the rear by pushing on the two notched portions in the direction of the arrows.

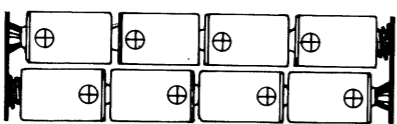
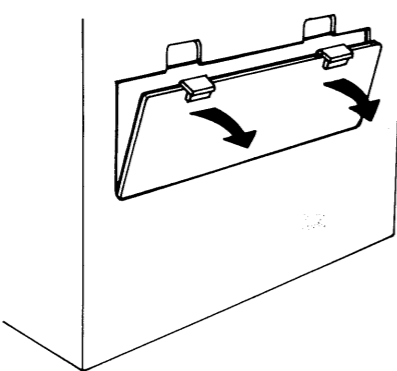

Insert eight SUM-1 ("D") batteries into the compartment, correctly matching the polarity markings inside the compartment. When the RPM-10(S) is not used for a long period, or is operated extensively on AC power, be sure to remove batteries. This will prevent possible

trouble caused by battery leakage.

### NOTE FOR THE 12V BATTERY INPUT

The 12V input not being provided with a Fuse in the equipment. The fuse must be inserted in the Circuit between external battery and 12V input.

**Note:** When the batteries grow weak, sound quality will deteriorate and/or the tape transport motion will become unstable. Weak batteries should be promptly replaced with new ones. Be absolutely certain to replace ALL eight batteries at once.

When making an important recording, it is advisable to use new batteries to insure optimum performance.

### • 12V Car Battery

By using a car battery cord, the RPM-10(S) can be powered through the cigarette lighter socket of a car. (The unit cannot be operated on 24-volt type car battery.)

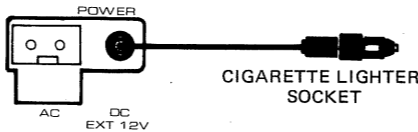

To connect the car battery cord, insert the larger plug into the cigarette lighter socket, and the other plug into the DC IN socket on the RPM-10(S). Be sure the AC power cord is disconnected from the main unit when using the car battery cord. When the car battery cord is connected, internal batteries (if present) are automatically disconnected.

## SPEAKERS

The accompanying speakers can be either attached to the main unit or separated from it. That speaker with the mounting plate on the right side (as seen from the front) is the left-channel speaker, and the other, with mounting plate on left, is the right-channel speaker.

### Attaching Speakers to the Main Unit

Mount both speakers on the main unit by fitting the hole of the speaker mounting plate onto the shaft joint of the main unit carrying handle. Next, lay out the combined components with rear panel down. Locate the two speaker fixing plates on the bottom of the unit. Loosen the screw on each fixing plate. Slide out each plate, and hook the hole in the plate onto the dowel provided on the bottom of speaker. Then, slide each plate back until the speaker comes in firm contact with the main unit.

Tighten both screws to fix the speakers securely in place.

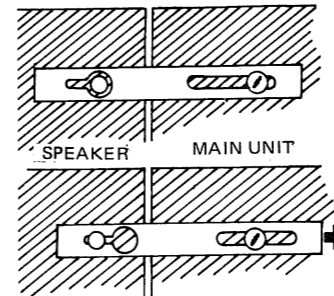
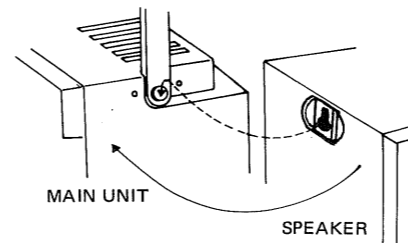

### Connecting Speaker Cables

Using the supplied speaker cables, connect the left-channel speaker to the left-hand speaker terminals on the rear of main unit, and the right-channel speaker to the right-hand speaker terminals, correctly matching the polarities.

To hook up the cable with the terminal, insert the end of the cable into the hole while pushing on the button. Then release the button. The cable should be firmly fixed in place.

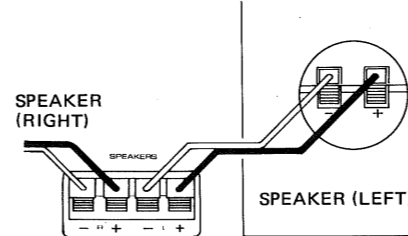

## CONNECTING TURNTABLE

Connect the two pin plug cords extending from the turntable to the PHONO terminals on the rear of the main unit, making correct left (L) and right (R) channel connections. Then connect the grounding wire of the turntable to the GND terminal.

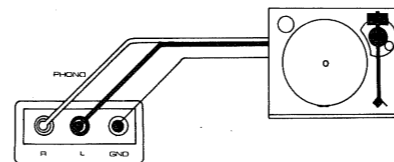

## ANTENNA

### FM

On the rear of the main unit is an FM rod antenna. For FM reception, pull up and extend the antenna, and adjust its length, angle and orientation until optimal reception is obtained.

**Caution:** Do not carry the unit while the FM rod antenna is in raised position, to prevent damage to the antenna.

### AM

An AM ferrite bar antenna is built into the main unit. The FM rod antenna is not effective for AM reception.

The internal AM antenna is directional, so when AM reception is difficult, try rotating the unit horizontally to change antenna orientation.

### External FM Antenna

If you are in a steel-frame building or considerably far from broadcasting stations, the unit rod antenna may not provide satisfactory FM reception. In that case, connect an external FM antenna to the antenna terminals on the rear panel.

Use terminals labeled "75Ω" for 75-ohm coaxial cable: Connect the center conductor of the cable to the left-hand terminal, and connect the outer braided conductor of the cable to the right-hand terminal.

Use terminals labeled "300Ω" to connect antenna with feeder wires.

**Note:** If your unit has a coaxial connector, attach an adaptor to the coaxial cable and insert the adaptor into the connector.

## AUTOMATIC SHUTOFF SYSTEM OF CASSETTE DECK SECTION

To protect the RPM-10(S) motor and transport mechanism against unnecessary wear, an automatic shutoff device has been built into the unit. When either end of tape is reached in play, record, fast-forward, or rewind mode, the

motor and mechanism will automatically shut off, disengaging the present mode.

## CASSETTE TAPES

• To prevent possible trouble with the transport mechanism, use of large size cassette tapes, such as C-120, is not recommended.

• Handle cassette tapes with care. Keep them away from heat, circulating dust, or a magnetic field (e.g. on the TV set).

• Each cassette tape has safety tabs on its back edge to prevent accidental re-recording. The tabs are provided for both sides of cassette tape. You cannot record on the side whose tab has been removed. The tab can be removed with a screwdriver, etc. If you wish to record on the side with no tab, place a piece of adhesive tape, etc. over the opening where the tab has been, then you can record.

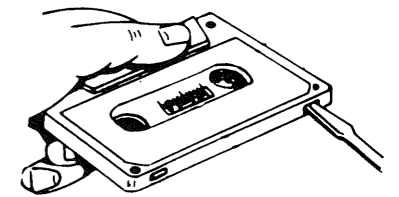

• A loosened tape may cause trouble in playback or recording. Check the tape before loading it into the deck. If it is slack, insert a pencil or the like into either of cassette's hubs, and rotate it carefully until the slack is taken up.

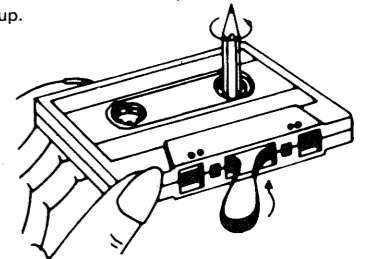

## EXCLUSIVE NOTES FOR THE U.S.A.

### Outdoor Antenna Grounding

If an outside antenna is connected to the receiver/tuner, be sure the antenna system is grounded so as to provide some protection against voltage surges and built up static charges. Section 810 of the National Electrical Code, ANSI/NFPA No. 70-1978, provides information with respect to proper grounding of the mast and supporting structure, grounding of the lead-in wire to an antenna discharge unit, size of grounding conductors, location of antenna-discharge unit, connection to grounding electrodes, and requirements for the grounding electrode. See figure.

a. Use No. 10 AWG copper or No. 8 AWG aluminum or No. 17 AWG copper-clad steel or bronze wire, or larger as ground wires for both mast and lead-in.

b. Secure lead-in wire from antenna to antenna discharge unit and mast ground wire to house with stand-off insulators, spaced from 4 feet (1.22 meters) to 6 feet (1.83 meters) apart.

c. Mount antenna discharge unit as closely as possible to where lead-in enters house.

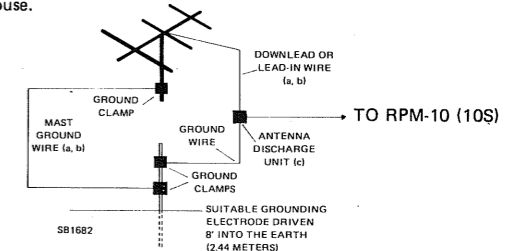

## SWITCHES AND CONTROLS

### (1) Power Button

Press the power button to turn on the unit. When the power is on, the dial pointer LED will glow. Press the button a second time to turn off the power.

### (2) Bass/Treble Tone Controls

Two separate controls regulate bass and treble respectively. BASS is for the low frequency range and TREBLE for high frequency range. Turn each knob clockwise to increase the response, and counterclockwise to reduce it. A flat response is obtained when both controls are at zero position. Use the controls effectively according to your taste or room conditions to achieve optimal sound performance.

### (3) Balance Control

In the central position, sound is produced in equal level from both speakers, while turning it to the right decreases the sound from the left speaker, and turning it to the left decreases the sound from the right speaker.

### (4) Dial Scale and Dial Pointer

The dial scale indicates frequencies for FM, MW, and LW bands on RPM-10; and FM, MW, and SW bands on RPM-10S.

### (5) Mode Selector

Selects reproducing mode. When set to WIDE, a stereo program will be reproduced with wider stereo effect, as if the distance between the speakers were increased. This position is recommended when you listen with the speakers mounted on the main unit.

In STEREO position, the unit gives normal stereo reproduction. Select this position when the speakers are not mounted directly on the main unit and are positioned at an appropriate

distance from each other.

In MONO/MUTE OFF position, any program will be reproduced monaurally. Also, the muting function (suppression of interstation noise), which is automatically activated in FM reception, will be cancelled out. Use this position when FM signal is weak.

### (6) Function Selector

Set this selector to PHONO when playing records, to TUNER when listening to radio broadcasts, and to TAPE when listening to tapes.

### (7) Band Selector

Used to select the desired band when listening to radio broadcasts.

### (8) Loudness Switch

The human ear has a tendency to become less sensitive to very low or high frequencies when listening at reduced volume levels. This switch activates a compensation function that boosts those frequencies so that a more natural sound is heard.

### (9) Stereo Indicator

Glow when stereo broadcasting signal is tuned in. Note that when stereo signal is very weak, the unit will not give stereo reproduction, and the indicator will not light up.

### (10) Signal Strength Indicator

The three LEDs show incoming signal strength; the receiving condition is optimal when all three LEDs are illuminated.

### (11) Volume Control

This knob regulates the volume level. Rotate the knob clockwise to raise the volume level, and counterclockwise to reduce it. When the knob is tuned fully counterclockwise, no sound is produced. Always have the volume

control set to minimum before you turn on power.

### (12) Tuning Knob

Use this knob to tune in to radio broadcasts.

### (13) Microphone Jacks

When making live recording with stereo microphones, insert the microphone plugs into these jacks. Make sure the right-hand microphone is connected to the right channel jack, and the left-hand microphone to the left channel jack. Be sure to unplug the microphones when recording from other sources.

### (14) Headphone Jack

For private listening, plug your headphones into this jack, which cuts off the sound from speakers. The volume of the headphone sound can be regulated with the volume control.

### (15) EJECT Button

Press this button to open the cassette holder for insertion or removal of cassette tape.

### (16) Cassette Controls

#### REC Button

To record, press this button. The deck is now in the recording mode, and the tape should be winding. The REC indicator glows during recording.

#### PLAY Button

Press this button to start the cassette for playback of prerecorded tape.

#### Rewind Button (◀)

For rapid tape rewind, press this button.

#### Fast Forward Button (▶)

Press this button to advance the tape rapidly forward.

#### STOP Button

Press this button to stop the tape in any mode: record, playback, rewind, or fast-forward. This button will release any transport mode currently engaged.

### PAUSE Button

Press this button to stop the tape temporarily during recording or playback. When this button is pressed, the PAUSE indicator glows. Pressing the button a second time will restart the tape in the interrupted mode.

### (17) Cassette Holder

Cassette tape is inserted into this holder. To open the holder, press EJECT button; and to close, push back the holder.

### (18) Function Indicators

The LED indicator labeled REC glows during recording. The indicator labeled PAUSE glows when the unit is in pause mode.

### (19) Dolby NR Indicator

Glow when Dolby NR switch is turned on, indicating the unit is in Dolby NR recording or playback mode.

### (20) Peak Level Indicator

Gives instantaneous display of recording or playback level for both left and right channels.

### (21) Tape Counter and Reset Button

The three-digit tape counter indicates the amount of tape travel. Push the reset button to set the counter to "000". This counter is convenient in finding the beginning of a specific section of the tape or checking the amount of the remaining tape on the cassette.

### (22) Recording Level Control

Used to control the recording level of incoming signals, such as from the unit's tuner section, turntable, or microphones. This is a dual concentric knob which permits either separate or combined adjustment of both channels.

### (23) Tape Selector

Used to select the appropriate recording bias and playback equalization, according to type of cassette tape used. Set the selector to METAL for metal particle tape, to SPECIAL for chromium dioxide tape, and to NORMAL for "normal" tape. See TAPE SELECTOR SETTING GUIDE for details of different brands of cassette tapes and their proper setting positions.

### (24) Dolby NR Switch

Set this switch to ON to activate the built-in Dolby NR circuit provided for high-frequency range noise reduction when you wish to record or play back through Dolby NR circuit.

### (25) Beat Cancelling Switch (On the rear panel)

When you are recording AM broadcasts, under certain circumstances the sound may seem to undulate. If this type of interference (called "beat") occurs, try changing the setting of the beat cancelling switch, which may eliminate the interference.

### (26) FM Rod Antenna

Used in FM reception.

### (27) Carrying Handle

### (28) Speaker System

Can be mounted onto the main unit or placed at a distance from it. (See section "SPEAKERS".)

## OPERATION

- Before commencing operation, check to see that all connections are properly made.

- Always be sure to set the volume control to the minimum position before turning on power.

- Set tone controls and loudness switch as desired.

### Listening from Turntable

1. Set function selector to PHONO.
2. Start the play on the turntable, then raise the volume to the desired level.

### Radio Broadcasts

1. Set function selector to TUNER.
2. On RPM-10, set band selector to LW, MW or FM; and on RPM-10S, set the selector to SW, MW or FM.
3. Tune in to the desired station with the tuning knob.
4. Raise the volume to the desired level.

**Note:** When receiving FM radio broadcast, lift up and extend the FM rod antenna, and adjust the angle, length, and direction of the antenna while checking on the signal strength indicator until optimal reception is obtained.

When receiving a weak FM broadcast, the mode selector should be set to MONO/MUTE OFF position; if the mode selector is set to WIDE or STEREO, weak broadcasting signal may be cancelled.

In the case that satisfactory FM reception is difficult in your area, use of external antenna is recommended.

### Operating Tape Deck Section

#### ■ Before Recording or Playback

1. When recording, be sure the safety tabs on the cassette tape are not removed.
2. Be sure to unplug the microphones from the deck when recording from other sources.
3. To insert a cassette tape, press the EJECT button to open the cassette holder, and gently insert the cassette into the holder, with the exposed tape side down and the side you wish to hear or record facing you. Then push the holder closed.

#### ■ Recording

- When recording with microphones, the microphone plugs must be inserted properly into the left and right microphone jacks.

- When you record from line source, be sure that the microphone plugs are disconnected from the microphone jacks.

Receive radio broadcast or play record for recording.

1. When you wish to record using Dolby NR circuit, turn on the Dolby NR switch.
2. Set the Tape Selector according to the type of tape used.

3. Press PAUSE button, then press REC button.

4. Adjust the recording level for left and right channels with Recording Level control so that the level indicator readings do not exceed 0dB position frequently, and when they do, only very briefly.

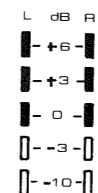

5. After adjusting recording level, press the PAUSE button again to put the unit into recording mode and to start the tape.

6. Carefully watch the meter indication during recording as well. PAUSE button may be used to temporarily halt recording.

7. Press STOP button when recording is finished. When the end of the tape is reached, the recording mode will automatically disengage and tape stops.

#### ■ Playback

1. When using tapes recorded through Dolby NR circuit, set the Dolby NR switch to ON. For tapes not recorded through Dolby NR circuit, set the switch to OFF.

2. Set the tape selector to match the type of tape used.

3. Press PLAY button and playback will begin.

4. To momentarily halt playback, press the PAUSE button. When you wish to end playback, press the STOP button. When the tape comes to an end, it stops automatically and playback mode is disengaged.

## HEAD CLEANING

The most frequent cause of failure to record in one or both channels, or of weak, distorted sound, is dirty tape heads and capstan. So, be sure to clean the heads, capstan, pinch roller and tape guides as often as possible using a "Q" tip dipped in ordinary rubbing alcohol or commercial liquid tape head cleaner. Thoroughly wipe the surface of the heads, capstan, roller and tape guide.

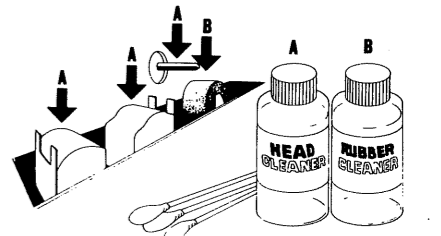

## HEAD DEMAGNETIZING

The tape heads, capstan and tape guides gradually become magnetized with use, which will eventually affect the sound quality of your tapes. Demagnetizing should follow cleaning, but need not take place as often as cleaning, once after every 20 to 30 hours of use should suffice.

A demagnetizer may be purchased at a moderate cost from any dealer carrying tape recording accessories. Follow the instruction supplied with the demagnetizer.

**Caution:** Be sure to turn off the unit before you attempt demagnetizing.

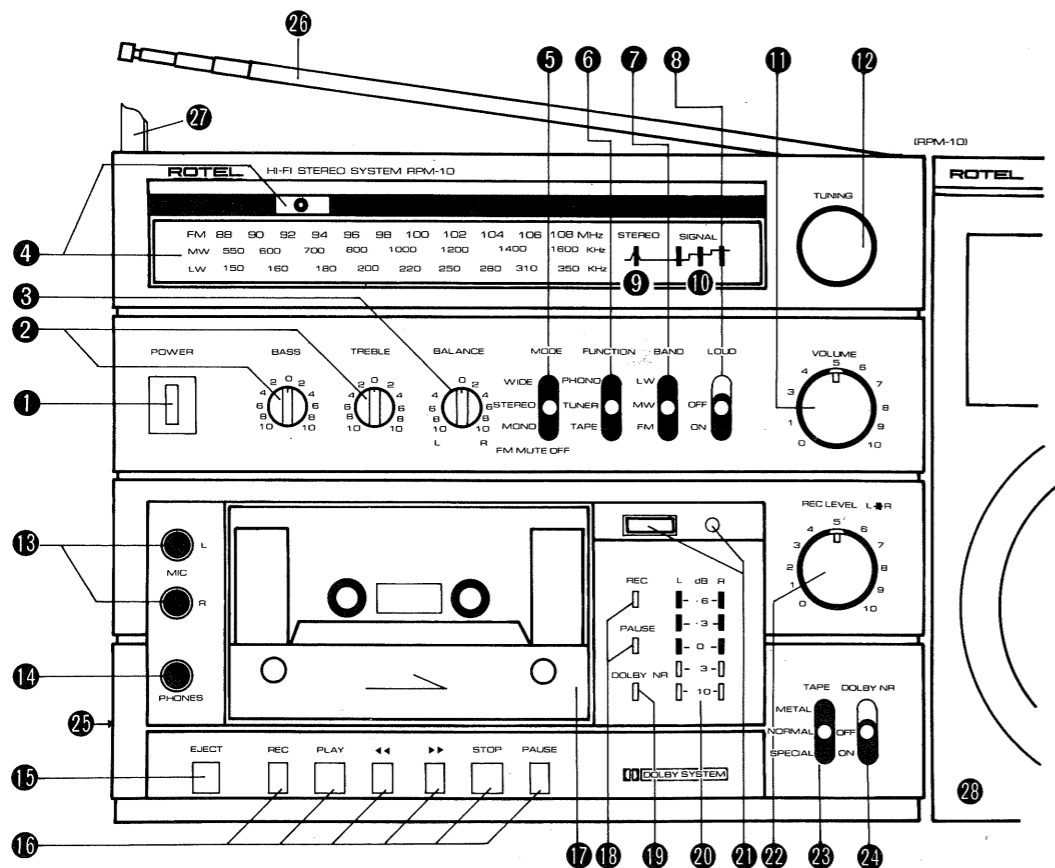

## SPECIFICATIONS

### AMP SECTION

Continuous Power Output	25 watts* per channel (music power) AC 15 watts* per channel RMS (DIN) AC. 12 watts* per channel, min. RMS both channels driven into 8 ohms from 40 to 20,000Hz with no more than 1.0% total harmonic distortion (AC). 5 watts* per channel, min. RMS both channels driven into 8 ohms from 40 to 20,000Hz with no more than 1.0% total harmonic distortion (DC 12V, dry cell batteries).
25 WATTS* per channel (music power) AC.	
15 WATTS* per channel RMS (DIN) AC.	
Total Harmonic Distortion (20 to 20,000Hz, from AUX)	No more than 1.0% (continuous rated power output)
Intermodulation Distortion (60Hz : 7kHz = 4 : 1)	No more than 1.0% (continuous rated power output)
Damping Factor	.19 (1kHz, 4 ohms)
Input Sensitivity/Impedance:	
PHONO	.25mV/47 k ohms
Overload Level (T.H.D. 1.0%, 1kHz):	
PHONO	.80mV
Tone Control:	
BASS	±10dB, 100Hz
TREBLE	±10dB, 10kHz
Loudness Contour (volume control set at -40dB position)	+7dB (100Hz), +3.0dB (10kHz)
Signal-to-Noise Ratio (IHF, A network):	
PHONO	.75dB

- \*Measured pursuant to the Federal Trade Commission's Trade Regulation Rule on Power Claims for Amplifiers (applicable to the U.S.A. only).

### FM TUNER SECTION

Usable Sensitivity (mono)	.11.2dBf (2.0μV/300 ohms)
Signal-to-Noise Ratio (at 65dBf):	
Mono	.65dB
Stereo	.60dB
Harmonic Distortion (at 65dBf):	
100Hz	.0.3% (mono), 0.5% (stereo)
1kHz	.0.3% (mono), 0.5% (stereo)
6kHz	.0.4% (mono), 0.6% (stereo)
Frequency Response	.35 to 14,000Hz, +1.5dB, -1.5dB
Capture Ratio	.2.0dB
Spurious Response Ratio	.70dB
Image Response Ratio	.45dB
IF Response Ratio	.70dB
AM Suppression Ratio	.55dB
Stereo Separation	.40dB (1kHz), 35dB (250Hz-6,300Hz)
Antenna Input	.300 ohms balanced, 75 ohms unbalanced

### AM TUNER SECTION (RPM-10)

Sensitivity	.MW: 300μV/m (IHF, ferrite antenna) LW: 1000μV/m
Selectivity	.30dB
Signal-to-Noise Ratio	.45dB
Image Response Ratio	.35dB (MW), 45dB (LW)
IF Response Ratio	.35dB
Antenna	.Built-in ferrite loopstick antenna

### AM TUNER SECTION (RPM-10S)

Sensitivity	.MW: 300μV/m (IHF, ferrite antenna) SW: 25μV
Selectivity	.30dB
Signal-to-Noise Ratio	.45dB
Image Response Ratio	.35dB (MW), 9dB (SW)
IF Response Ratio	.35dB (MW), 40dB (SW)
Antenna	.Built-in ferrite loopstick antenna

## TAPE SECTION

Heads: Rec/Play	.High B permalloy laminated type
Erase	.Ferrite core
Track	.4-track/2-channel
Tape Speed	.4.8cm/sec.
Motor	.Electronic DC Governor
Wow and Flutter	.0.1% (DIN) 0.05% (WRMS)
Distortion (REC/PB, 333Hz)	.0.6% (METAL)
Frequency Response (-20dB)	.Normal, LH 30 to 14,000Hz±3dB Special 30 to 15,000Hz±3dB Metal 30 to 16,000Hz±3dB
Signal-to-Noise Ratio (WTD, 0dB=580mV, Chromium)	.Dolby NR in: 64dB Dolby NR out: 55dB
Input Sensitivity/Impedance	.MIC 0.3mV/10 kohms LINE 25mV/47 kohms
Fast Wind Time (C-60)	.80 seconds
Tape Selector	.BIAS EQUALIZER
Normal, LH	.100% 120μs
Special	.150% 70μs
Metal	.200% 70μs

## MISCELLANEOUS (excluding speakers)

Power Requirement	.120V/60Hz, or 240V/50Hz
Power Consumption	.81 watts
Dimensions (overall)	.281 (W) x 229 (H) x 218 (D) mm 11-1/16" x 9" x 8-19/32"
Weight (net)	.5.4kg/11.9 lbs

## SPEAKER SECTION

Enclosure Type	.Air suspension
Speaker Units	.4" woofer, 2-1/4" tweeter
Nominal Impedance	.8 ohms
Maximum Input Power	.25 watts (peak), 15 watts (RMS)
Frequency Response	.70-18,000Hz
Crossover Frequency	.3,300Hz
Sensitivity	.92dB/W
Dimensions	.W 140mm x H 234mm x D 211mm 5-1/2" x 9-7/32" x 8-5/32"
Weight	.2.3kg/5.1 lbs.

- Specifications and design subject to possible modification without notice.
- Dolby and the double-D symbol are trade marks of Dolby Laboratories Licensing Corporation.  
Noise reduction system manufactured under license from Dolby Laboratories Licensing Corporation.

TAPE SELECTOR SETTING GUIDE

TDK	OD, AD	NORMAL
FUJI FILM	ER, DR	NORMAL
SONY	AHF, BHF	NORMAL
MAXELL	UD, XL-I	NORMAL
SCOTCH	MASTER I	NORMAL
BASF	Super LH-I, LH	NORMAL
TDK	SA, SA-X	SPECIAL
FUJI FILM	UR	SPECIAL
SONY	JHF	SPECIAL
MAXELL	XL-II, X II-S	SPECIAL
SCOTCH	MASTER II	SPECIAL
BASF	SCR	SPECIAL
TDK	MA	METAL
FUJI FILM	SUPER RANGE	METAL
SONY	METALLIC	METAL
MAXELL	NEW-MX	METAL
SCOTCH	METAFINE	METAL