

ROTEL[®]

SOLID STATE STEREO AMPLIFIER

OPERATING MANUAL _____

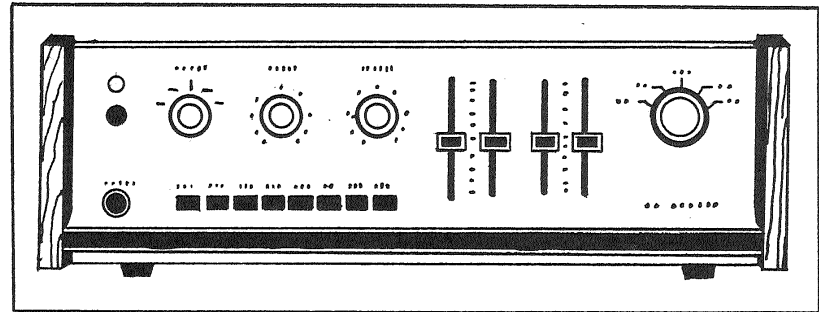

RA - 610

INTRODUCTION

We would like to take this opportunity to thank you for purchasing our ROTEL RA-610 STEREO PRE-MAIN AMPLIFIER. In RA-610 you have the finest equipment available in the Hi-Fi components field. With the quality workmanship that goes into making the RA-610, you can be assured of its flawless performance for many years to come.

The RA-610 is equipped with every conceivable control and feature any demanding audiophile ever hopes of having on his unit. The RA-610 was designed for both the versatility and ease of operation. It will add professional studio flexibility to your present music center.

The performance of RA-610 is exceptional; it will allow you to experience true high fidelity as never before. Its full and natural stereophonic reproduction offers you musical entertainment rivaling that of live performances. We sincerely hope you will treasure this professional equipment.

In order to obtain the maximum use out of your unit, please read all of the following pages of this Operation Manual carefully.

Do not attempt to operate the unit until you have made all the connections as specified in this Manual.

SPECIAL FEATURES

- 1) Direct Coupling Output Circuit eliminates the need for an output capacitor, thereby, permitting better frequency response at lower IM distortion.
- 2) Differential Amplifier provides higher stability and lower distortion.
- 3) Split Power Supplies for left and right channels decrease frequency damping factor and overall distortion.
- 4) Tone Defeat switch offers absolute flat response.
- 5) – 20 dB Muting switch provides instantaneous quietness.
- 6) Tape Monitor switch for tape playback and recording.
- 7) Dual Slide Tone Controls for Bass and Treble offer easy and accurate tone adjustment.
- 8) High and Low Filter switches, – 9 dB cutoff, for eliminating rumble and scratch noises.
- 9) Loudness switch for boosting extreme low frequencies during low volume operation.
- 10) Two pairs of magnetic input jacks for two sets of record players with different input impedances.
- 11) Pre-amplifier Outputs for use with separate power amplifier or multi-channel system.
- 12) Main-amplifier Inputs for use with separate control amplifier or tape recorder.
- 13) Front Panel Stereo Headphone Jack for easy use.
- 14) Two Speaker Selector switches for individual or simultaneous operation of two speaker systems.
- 15) Handsome Wood Cabinet.

INSTALLATION

IMPORTANT

Do not apply power to this unit without first making sure that both speakers are connected properly. Before attempting to operate the RA-610, please read the following instructions carefully. When all the necessary connections are made, the power may be applied.

SPEAKER CONNECTIONS

The RA-610 has connections for two pairs of stereo speaker systems. Make sure that your main speakers are connected to the SYSTEM-1 terminals and the remote speakers to the SYSTEM-2 terminals.

Connect the left hand speaker leads to the terminals designated LEFT SPEAKERS and the right hand speaker leads to the RIGHT SPEAKERS.

With the RA-610 any speaker system of 4, 8 or 16 ohm impedance can be used.

NOTE: Be sure that all the speaker leads are fastened securely to the proper terminals and that there are no stray strands shorting one terminal with another.

PHASING

In a stereophonic music reproducing system, the two speakers must be properly connected to assure complementary functioning. Make sure that the terminals on the speakers are connected to the corresponding terminals on the amplifier. If the two speakers are out of phase with each other, the stereophonic effect will suffer and the low frequency response will be particularly poor. Check to make sure that your speakers are in phase.

1. Push the MODE button "IN" for monophonic operation.
2. Play a monophonic source with solo singing or instrument.
3. If the speakers are in phase, the sound will appear to come from the exact center between the two speakers, and if the speakers are out of phase, the sound will appear to come from the two speakers separately.
4. If the speakers are out of phase, reverse the connections of the two speaker leads (from only one of the speakers, although it may be either one) at the RA-610's speaker terminals. The speakers will then be in phase with each other.

TUNER CONNECTIONS

Connect the Right and Left leads from your tuner to the corresponding terminals on the RA-610. With a monophonic tuner the output lead may be connected to either one of the terminals, RIGHT or LEFT.

RECORD PLAYER CONNECTIONS

The shielded cables from your stereo record player should be terminated with RCA type phono plugs. To avoid loss in the high frequencies, the cables should not exceed 10 feet in length. The RA-610 is equipped with inputs for two stereo record players, one for record players with magnetic cartridge of 100 k ohm input impedance and the other for record players with magnetic cartridge of 50 k ohm input impedance.

TAPE RECORDER CONNECTIONS

Outputs from stereo tape recorders having their own pre-amplifiers should be connected to the high level input terminals marked TAPE IN. For recording purposes, the tape recorder's Input should be connected, using shielded cables, to the output terminals marked TAPE OUT. The RA-610 is also equipped with DIN type terminals for connecting stereo tape recorder with DIN type plugs.

AUXILIARY INPUTS

Two sets of jacks marked AUX-1 and AUX-2 are provided for any other high level source you wish to run off the RA-610. You may connect a tape recorder for playback, a ceramic microphone, a second tuner, sound from a TV set, a cassette tape player or an 8-track tape player.

PRE-AMPLIFIER OUTPUT AND MAIN-AMPLIFIER INPUT

There are two sets of jacks marked PRE-AMPLIFIER OUTPUT and MAIN-AMPLIFIER INPUT, connected with a pair of Jumper Cables, on the rear panel. This unique ROTEL feature permits flexible use of the RA-610. Normally, with the Jumper Cables in place, the RA-610 is an integrated unit consisting of pre- and main- amplifier sections, but by removing the Cables, the RA-610 in essence becomes two independent units of one pre-amplifier and one main-amplifier. In this way the RA-610 can be used in various combinations with other components.

1. The RA-610's pre-amplifier section can be used with a separate main- (power) amplifier, in which case all of the control functions, e.g. volume, tone, etc., will remain operational. To effect this combination, first remove the Jumper Cables, thereby breaking the circuits between the pre- and main- amplifier sections, and secondly, using RCA pinjack-terminated cables, connect the PRE-AMPLIFIER OUTPUT on the RA-610 with the Input on the separate main-amplifier. Lastly, connect the speaker cables to the main-amplifier's Output terminals.
2. The RA-610's main-amplifier section can be used with a separate pre- (control) amplifier, in which case all of the RA-610's control functions, e.g. volume, tone, etc., will no longer be operational. To effect this combination, remove the Jumper Cables, and connect the MAIN-AMPLIFIER INPUT with the Output on the separate pre-amplifier. Then connect the speaker cables to the RA-610's speaker terminals.
3. For making tape recordings off of such sources as tuners, record players or other tape recorders, the RA-610 is equipped with both RCA pin and DIN type jacks for Tape Recorder Input and Output. This allows you to record the program signals straight off the source. However, you can run the signals from the source through the RA-610's pre-amplifier, so that you may "color" the signals before recording them. In other words, you may "color" the signals with the RA-610's volume and tone controls. To effect this combination, remove the Jumper Cables, and connect the PRE-AMPLIFIER OUTPUT with the Tape Recorder's Input and MAIN-AMPLIFIER INPUT with the Tape Recorder's Output.

AC OUTLET

The RA-610 is equipped with an AC Outlet (switched) to provide switching control and power to whatever component you may wish to connect to the RA-610.

GROUNDING

With record players or tape recorders that must be grounded to reduce hum to unobjectionable levels, connect any grounding wire to a screw terminal marked "GND" on the rear panel.

FUSE

The RA-610 is protected with one 3-ampere fuse in the AC primary and two 3-ampere fuses in the DC output circuits. Replacing with a fuse of higher rating will not protect the unit any more effectively, rather it may result in severe damage to the unit. (In 230V areas the AC fuse will be of 1.5-ampere rating, and DC fuses will remain at 3-ampere rating).

INTERCONNECTING DIAGRAM

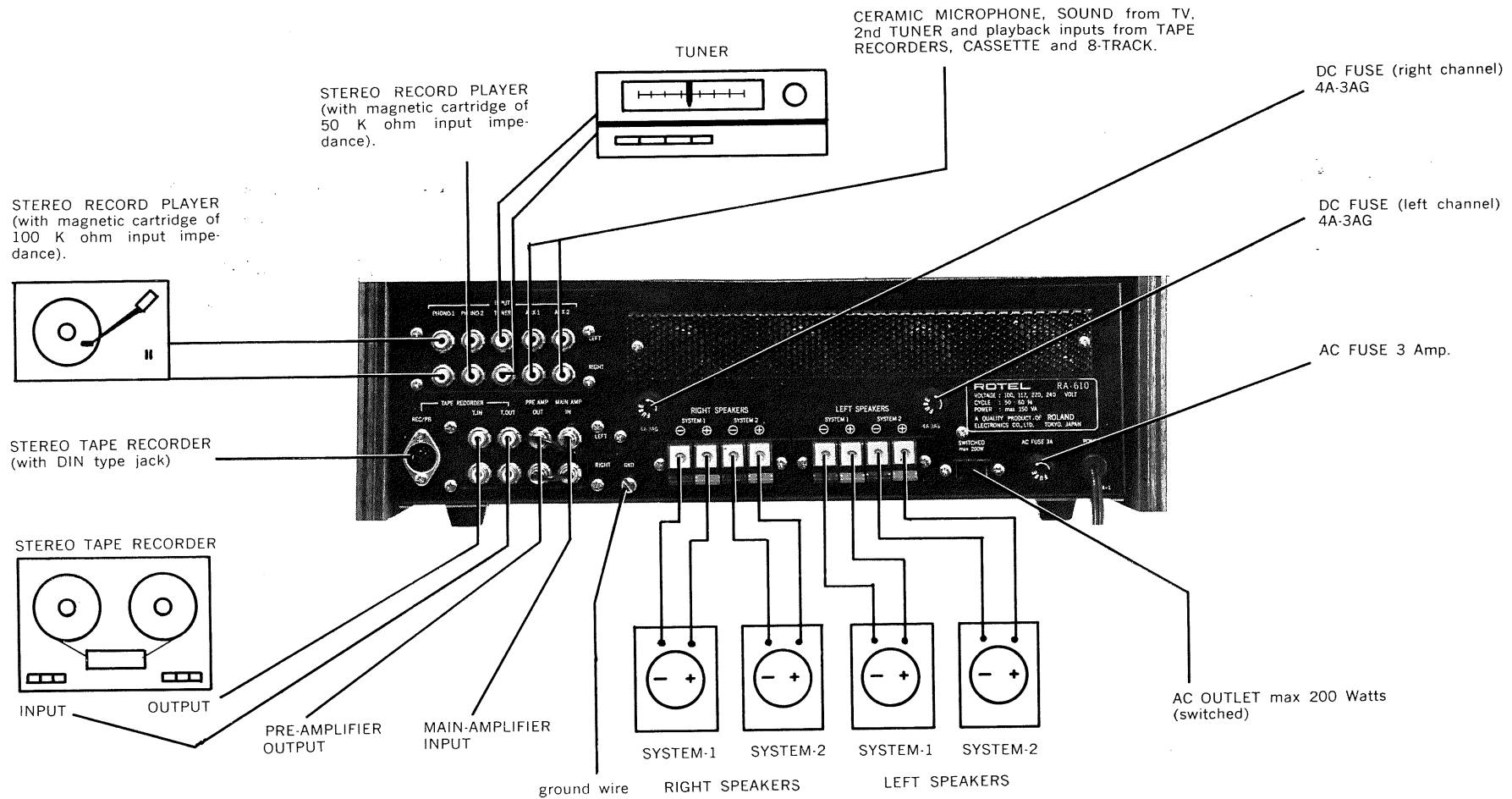

OPERATION

When all the connections have been made according to the preceding instructions, you may apply the power by pushing "IN" the POWER button. Select the speaker system you wish to activate by pushing "IN" either the SPEAKERS, SYSTEM-1 or SYSTEM-2 button, or if you desire to operate both the main and remote speaker systems simultaneously, push "IN" both the SYSTEM-1 and SYSTEM-2 buttons.

NOTE: If the Power Indicator Light fails to light, remove and check the AC fuse.

If no sound were heard even when all the buttons and controls are placed at their correct positions, remove and check the DC fuses. If a fuse is blown, check for possible reasons for the blow-out (e.g., short at the speaker leads, etc.), and replace the fuse.

RECORD PLAYER

Set the INPUT SELECTOR to PHONO-1 or PHONO-2 position, depending upon which record player you wish to operate, and turn the MODE SELECTOR knob to "REVERSE", "STEREO", "LEFT", "RIGHT", OR "MONO" depending upon your program source and your desire.

The MODE SELECTOR in "REVERSE" reverses the orientation of the two stereo channels. In "STEREO", the RA-610 is set for normal stereophonic operation. In "LEFT", it is set to reproduce only the signals from the Left Channel, and in "RIGHT" it is set to reproduce only the signals from the Right Channel. In "MONO", it is limited to normal monophonic operation.

Set the BASS and TREBLE Slide controls to suit your personal preference. The RA-610 is equipped with individual controls for RIGHT and LEFT Channels, so that you may set the BASS and TREBLE for two channels separately.

Adjust the BALANCE control to ensure proper balance between the speakers. Play a monophonic program source and adjust the control until, seated at your normal position, the sound seems to come out from the center between the two speakers.

TUNER

Turn the INPUT SELECTOR knob to "TUNER" position, and set the MODE SELECTOR to your choice as explained in the RECORD PLAYER section.

Set the BASS and TREBLE tone controls to your personal preference.

PLAYBACK OF TAPE RECORDING

To listen to a playback of pre-recorded tape, push the TAPE MONITOR button "IN". The setting of the INPUT SELECTOR control is irrelevant in this case and may be left at any position. The VOLUME, BASS, TREBLE, and BALANCE controls may be adjusted to suit your taste.

MAKING TAPE RECORDINGS

To make off-the-air recordings, turn the INPUT SELECTOR knob to "TUNER", and to record off phono records, set to PHONO-1 or PHONO-2. To "dub" off another tape recorder, set to "AUX-1" or "AUX-2" (the back panel connections should be made so that the "recording" tape recorder is connected to the TAPE IN and TAPE OUT jacks and the "playback" tape recorder to AUX-1 or AUX-2 jacks). Same procedure applies for recording off cassette or 8-track tape.

If your tape recorder is equipped with a separate playback head, pushing "IN" the TAPE MONITOR button will cause the input source to be bypassed and will permit you to listen to the recording being made on the tape. Leaving the TAPE MONITOR button "OUT" will permit you to listen to the input source.

Thus, with the TAPE MONITOR button you may "monitor" or compare the recording being made with the source being recorded.

MUTING

For momentary quietness during telephone calls or conversation, push "IN" the -20 dB MUTING button; it will instantly reduce the volume level to 1/10. Without having to reset the volume control, you may restore the volume level by pushing the button again to bring it to its normal "OUT" position.

HIGH FILTER

To eliminate high frequency noises, push the HIGH FILTER button "IN"; it is especially effective for elimination of high frequency noise interference from a Tuner and of "scratch" noises from a Record Player or Tape Recorder. To deactivate the filter, push the button again to bring it to its normal "OUT" position.

The cutoff is at 10,000 Hz / -9 dB.

LOW FILTER

To eliminate low frequency noises, push the LOW FILTER button "IN"; it is especially effective for elimination of "rumble" noises originating from a Record Player. To deactivate the filter, push the button again to bring it to its normal "OUT" position.

The cutoff is at 50 Hz / -9 dB.

HEADPHONES

To listen through a pair of headphones, simply plug the headphone lead into the PHONES jack on the front panel and leave the SPEAKERS, SYSTEM-1 and SYSTEM-2 buttons "OUT" to deactivate the external sound sources.

tone DEFEAT

To get an absolutely flat response throughout the entire frequency range of the RA-610, push "IN" the TONE DEFEAT button; it defeats the tone control functions of the BASS and TREBLE Controls. You may use the TONE DEFEAT to test for flatness of the BASS and TREBLE Tone Controls when their settings are at zero or for listening at absolutely flat level if you wish. To deactivate the TONE DEFEAT, push the button again to bring it to its normal "OUT" position.

LOUDNESS SWITCH

Whenever your system is operated at low levels, the sound will not seem as full as it is at higher levels. This is because the human ear does not perceive as well the low frequency sounds when the volume is low. The LOUDNESS button is used to compensate for this deficiency. Whenever the volume is reduced, push this button "IN", and the extreme low frequency sounds will be effectively boosted.

VOLTAGE SELECTION

Your RA-610 comes preset at the proper voltage for use in your area; however, if you move to an area where the power supply voltage is different, simply change the voltage setting. The RA-610 is a variable voltage amplifier that can run on 100V, 117V, 220V and 240V power supplies.

To change the voltage setting, remove the bonnet cover and locate the Voltage Selector (CAUTION: Be sure to disconnect your unit from the power source before attempting to remove the bonnet cover). The Voltage Selector Plug has a white arrow on its top. Reinsert the Voltage Selector Plug so that the arrow lines up with the Pointer Line of the voltage you desire.

CONTROLS AND THEIR FUNCTIONS

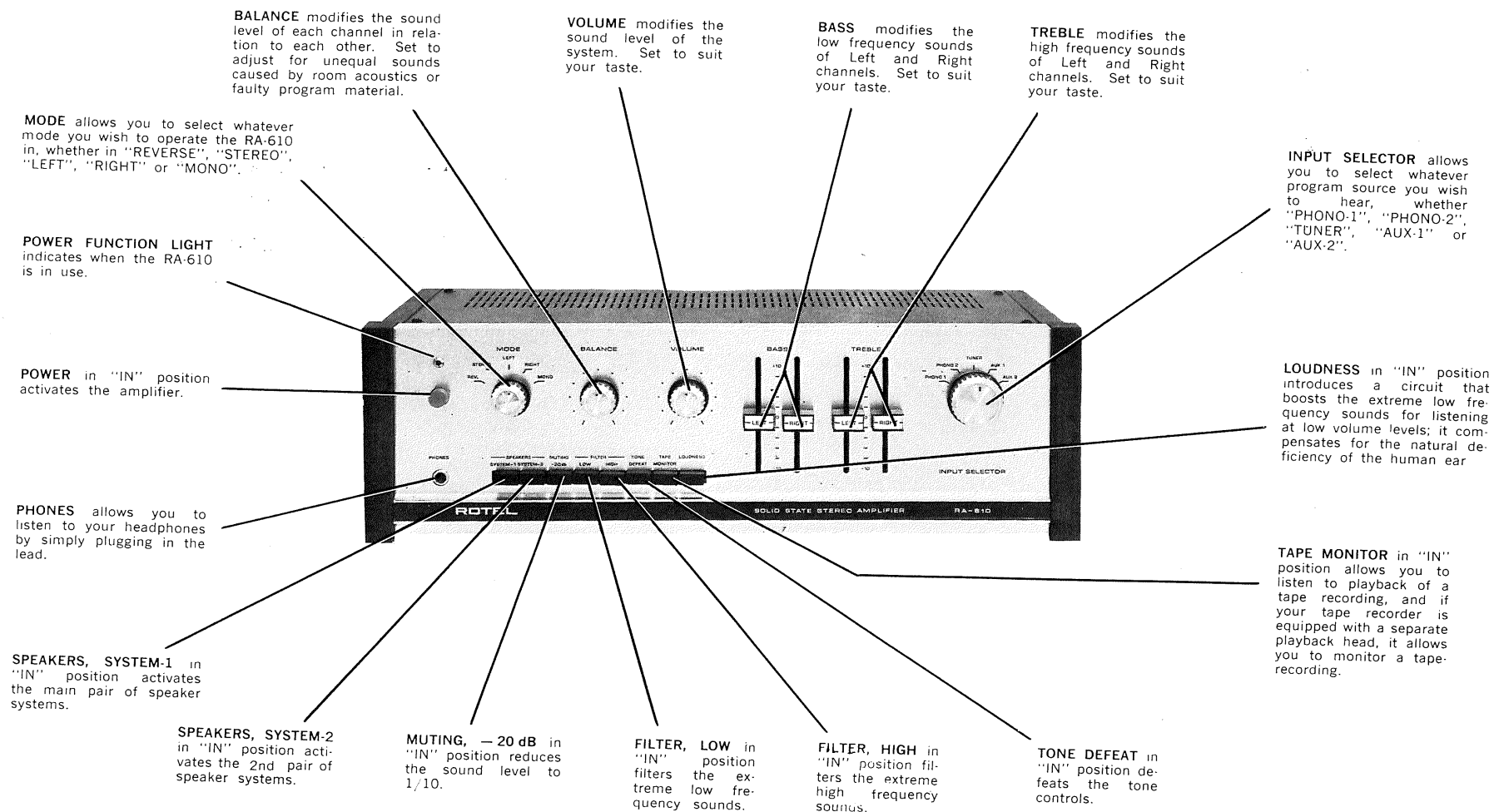

SPECIFICATIONS

POWER OUTPUT:

TOTAL MUSIC POWER (IHF):	120 watts at 4 ohms 90 watts at 8 ohms
CONTINUOUS POWER (RMS):	32 watts/channel, 8 ohms @ each channel driven

DISTORTION:

INTERMODULATION (IM):	less than 0.1% at rated output (70 Hz : 7,000 Hz 4 : 1)
HARMONIC:	less than 0.1% at rated output

FREQUENCY RESPONSE:

MAIN AMP. ONLY:	3 Hz to 100,000 Hz +0 dB to -3 dB
AUXILIARY INPUTS:	5 Hz to 90,000 Hz +0 dB to -3 dB

POWER BANDWIDTH (IHF):

3 Hz to 55,000 Hz

INPUT SENSITIVITY: (@ rated output)

PHONO-1:	2.5 mV
PHONO-2:	2.5 mV
TUNER:	120 mV
AUX-1:	120 mV
AUX-2:	120 mV
TAPE IN:	120 mV
MAIN AMP. INPUT:	650 mV

INPUT IMPEDANCE: (@ 1,000 Hz)

PHONO-1:	50k ohms
PHONO-2:	100k ohms
TUNER:	25k ohms
AUX-1, AUX-2, TAPE IN:	25k ohms
MAIN AMP. INPUT:	35k ohms

SIGNAL TO NOISE RATIO:

PHONO-1:	65 dB
PHONO-2:	65 dB
TUNER:	80 dB
AUX-1, AUX-2, TAPE IN:	80 dB
RESIDUAL:	1 mV

SQUARE WAVE RISE TIME:

2.2 microseconds

DAMPING FACTOR:

35 at 8 ohms
70 at 16 ohms

OUTPUT IMPEDANCE:

SPEAKER TERMINALS:	4, 8, 16 ohms @ full rating
PRE-AMP OUTPUT:	50 ohms

LOUDNESS SWITCH:

+10 dB at 50 Hz

HIGH FILTER:

-96 dB at 10 kHz

LOW FILTER:

-9 dB at 50 Hz

MUTING:

-20 dB at 1 kHz

BASS CONTROL:

+15 dB to -13 dB at 50 Hz

TREBLE CONTROL:

+14 dB to -16 dB at 10,000 Hz

PHONO OVERLOAD:

over 100 mV

PHONO EQUALIZER:

+17 dB at 50 Hz

CROSS-TALK:

60 dB at 1 kHz

DIMENSION:

16 $\frac{1}{4}$ " X 8 $\frac{3}{4}$ " X 4 $\frac{7}{8}$ "

WEIGHT:

13.2 lbs

SCHEMATIC DIAGRAM

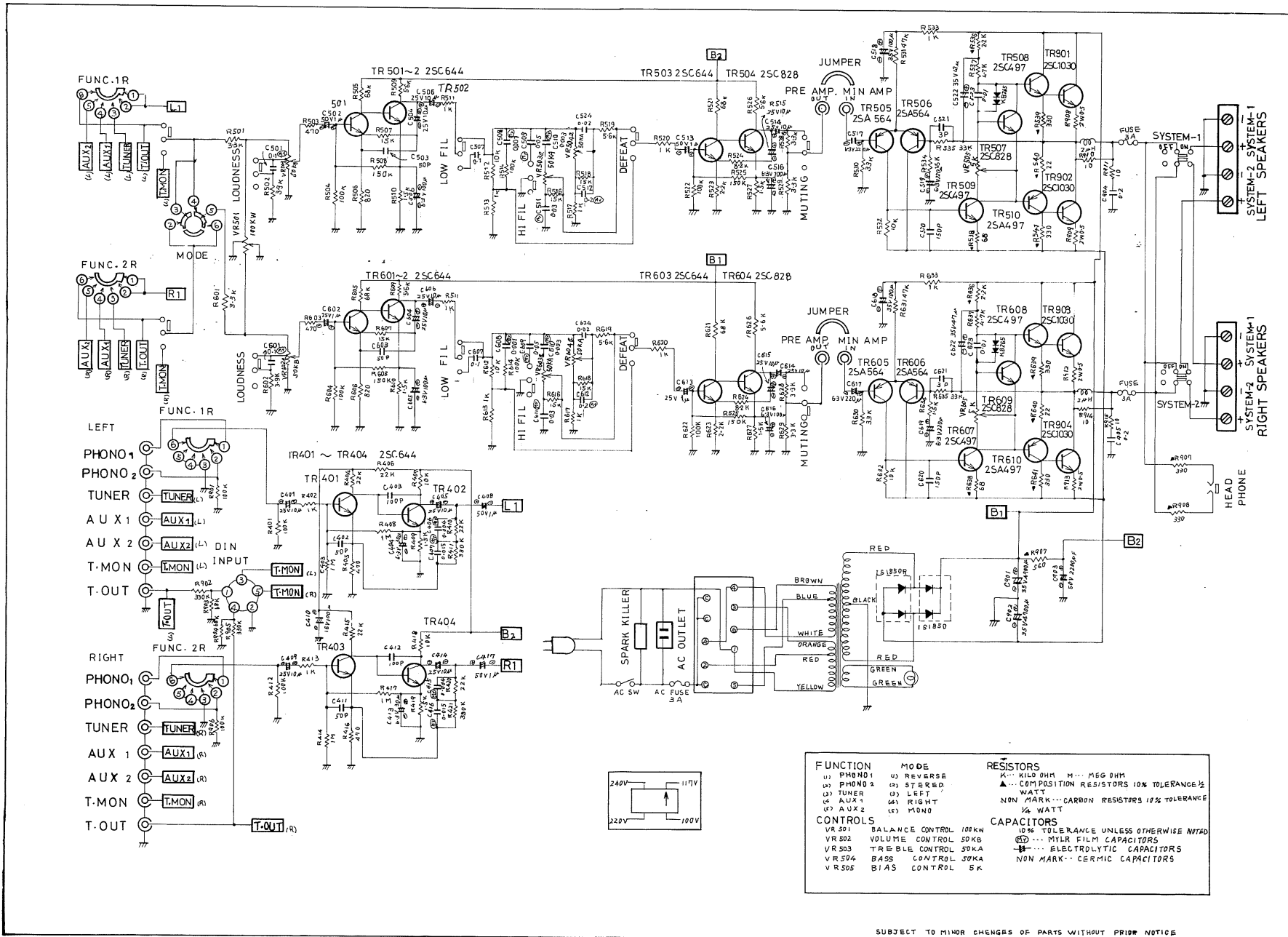

. . . AND A FINE SUGGESTION FROM ROTEL:

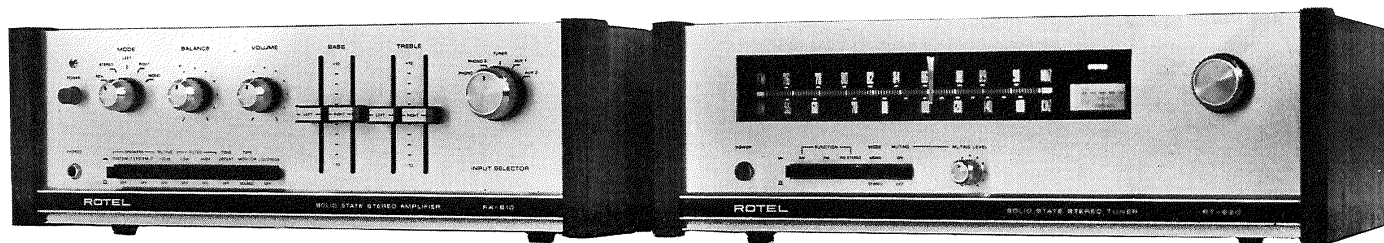

RA-610 STEREO PRE-MAIN AMPLIFIER

RT-620 AM/FM STEREO TUNER

In RA-610 you have made a fine choice of pre-main integrated amplifier from today's proliferating, often confusing, variety of Hi-Fi components that are available to the consumer. But if it is difficult to distinguish an excellent amplifier, it is even more difficult to select a tuner that is not only superior in itself but is truly suited to the amplifier. Every amplifier, including the RA-610, has its own unique characteristic, and for the RA-610 we cannot suggest to you a more fitting tuner than the ROTEL RT-620 AM/FM Stereo Tuner. The RA-610 and RT-620 were designed specifically to complement each other's characteristics and, hence, enhance each other's performance as no other combination of components can.

Some of RT-620's outstanding features:

FM section with FET Front-End

- 4-Gang Variable Capacitor
- 2-Stage RF Amplifier
- Ceramic Filters
- Variable Muting Control
- IHF Sensitivity of . . . 1.7 mV
- IHF Selectivity of . . . 60 dB
- Harmonic Distortion of . . . less than 0.3%

AM section with 3-Gang Variable Capacitor

- 1-Stage RF Amplifier
- Ceramic Filters

Variable Output Voltages for both AM and FM