

# Owner's Manual

Stereo Integrated Amplifier

# RA-312

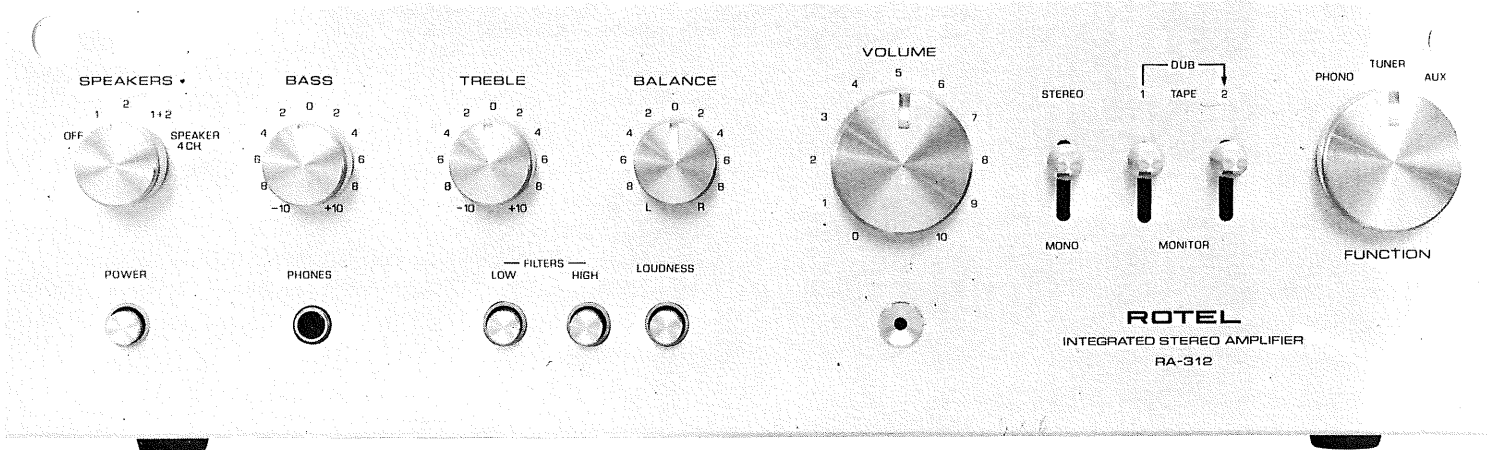

## ROTEL®

### INTRODUCTION

We would like to take this opportunity to congratulate you on your purchase of our audio component. With the latest technology and workmanship that goes into making this equipment, you can be assured of its high quality performance for many years to come.

We have fitted a comprehensive range of controls and features for your convenience. Designed for both versatility and ease of operation, this piece of equipment will add

professional studio flexibility to your Hi-Fi sound center. The performance is exceptional, allowing you to experience true high fidelity. Its full and natural sound reproduction offers you musical entertainment approaching that of live performances. We sincerely hope you will treasure this professional type component. In order to obtain the maximum use out of your equipment, we urge you to read the following pages of this Owner's Manual carefully.

### CONTENTS

- 2/3 SYSTEM CONNECTIONS  
BEFORE ENJOYMENT  
POWER SUPPLY CONNECTION  
LOCATING THE UNIT  
SPEAKERS PLACEMENT  
SPEAKER CONNECTING  
GROUND  
CONVENIENCE AC OUTLET
- 4/7 ALL ABOUT THE ROTEL RA-312  
SPECIFICATIONS  
BLOCK DIAGRAM  
FUNCTIONS & CONTROLS  
ADDITIONAL COMPONENTS
- 8 HUM AND NOISE  
EXCLUSIVE NOTE FOR U.K.

**WARNING – TO PREVENT FIRE OR SHOCK HAZARD, DO NOT EXPOSE THIS APPLIANCE TO RAIN OR MOISTURE.**



# System Connections

## BEFORE ENJOYMENT!

For safety sake keep in mind the following cautions:

1. Do not connect the unit to the AC power line without speakers connected beforehand.
2. Make sure also that the power switch is left off and the master volume control is set at minimum before plugging in the power cord to a wall outlet.
3. Speakers
  - a) **Impedance** - Be sure to use speakers rated at 8 ohms or higher up to 16 ohms. In the event your speakers are rated at 4 ohms or lower than desired 8 ohms, you may operate with one pair of such type of speakers at a time but never two pairs of speaker system simultaneously. This measure is to prevent any severe overload and distortions from happening due basically to too low impedance to draw excessively high current. When you are uncertain on your speakers rating values, consult with the dealer or store you purchased.
  - b) **Connection** - Before connecting speaker leads to the terminals on appliance make sure also no loose stray strands of wire is left in order to prevent any shorting between speaker leads or terminals to main chassis. This shorting malfunction may be common cause of blown fuses or overload.
4. Always use the fuse, if necessary to replace, of same type and rating as the one installed on the unit. Replacing fuse incorrectly with higher rating will defeat the purpose of protection and may cause severe damage instead.
5. **Furnished Convenience AC Outlet**
  - (a) Do not insert or remove plug from any convenience AC outlet supplied on the appliance while the appliance is connected to power. Also do not insert foreign object, other than a proper plug, into the convenience AC outlet.
  - (b) Do not connect other appliance(s) to convenience AC outlet if its/their total power consumption exceeds maximum rated watts labeled next to the outlet.

## POWER SUPPLY CONNECTION

For power the unit requires the normal house electrical current (AC). Simply plug the unit to a wall outlet.

If in any doubt about connecting to the power source, consult a qualified electrician.

**CAUTION** - Do not apply power to the equipment without first making sure that speakers are connected properly and that the unit's VOLUME control is set to minimum. If you live in U.K. and your unit comes with 3-core cord without a plug, be sure to read the last page of this manual before connecting to power.

## LOCATING THE UNIT

Although the unit normally does not develop high heat, it should be placed in such a way that its ventilation system will not be impeded. Place the unit on a hard surface - any conveniently located shelf or table where not affected by heat or moisture. Leave at least 5 cm (2 inches) clearance on each side and in the rear of the unit, and about 10 cm (4 inches) above the unit. Never directly place an object on the top of the unit.

## SPEAKERS PLACEMENT

**NOTE** - Check speakers' rated impedance as instructed on this page.

**1. MAIN SPEAKERS** - Referred to a pair of speakers connected to the SPEAKER 1 terminals on the unit's rear panel. Place the main speakers against a wall or on a shelf so that they face your selected listening position and are equal distance from you. For optimum stereo effect, they should be 3 to 4 meters (10 to 15 feet) apart and, if possible, at about ear level height. You may determine best locations to suit your personal tastes and listening conditions.

**2. REMOTE SPEAKERS** - If you wish to enjoy stereo sound in another room, you can connect another pair of speakers to the SPEAKER 2 terminals. Though you may require long cables between the unit and the

remote speakers, make sure they are not longer than 15 to 20 meters (50 to 60 feet) in length and that they are of heavy duty shielded type in order to prevent loss of volume level. Following the procedure described in the item 1 above for placing the remote speakers.

## SPEAKER CONNECTION

**Caution:** Do not apply power to the unit until the speakers are connected properly as described below.

As shown in Fig. 2, the speaker terminals are quick-connect push-insert type, and are arranged into two boards, one for SPEAKER 1 (main) and the other for

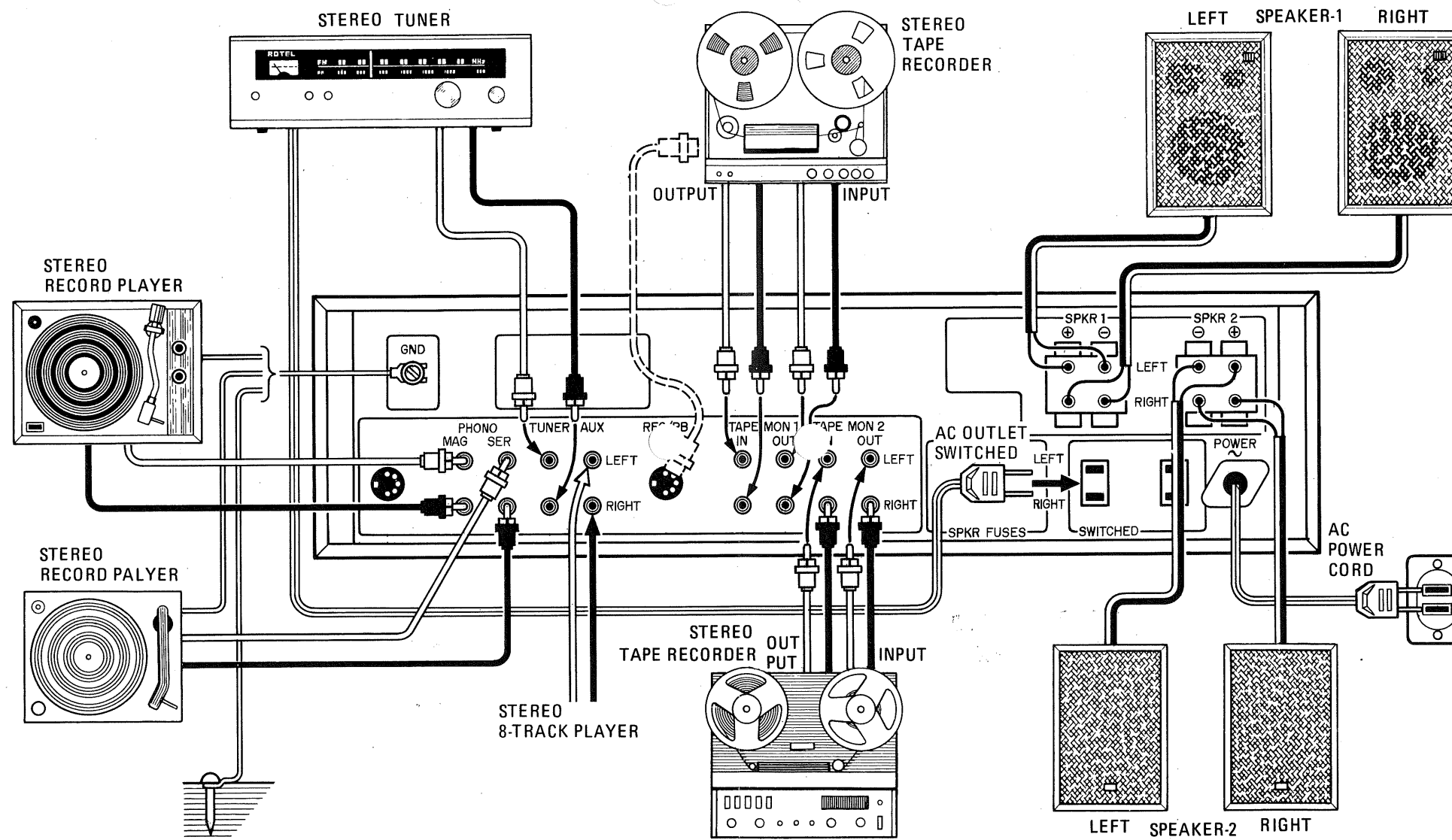

Fig. 1

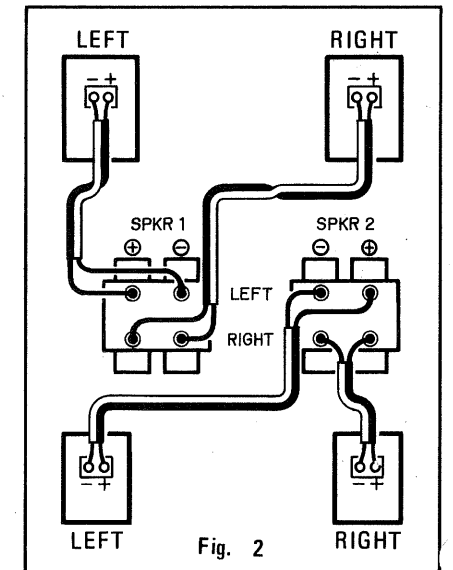

Fig. 2

SPEAKER 2 (remote). Push back the tab on each terminal, slip the bare wire at the free end of the speaker lead into the opened jaw of the terminal, and release the tab to grip the bare wire in the jaw. (Note: if necessary, after stripping each end of speaker leads to obtain a bare wire, twist the bare strands together so it will be easy to insert and also prevent shorting among stray strands.) Make sure the positive (+) lead of each speaker is connected to the (+) terminal and the ground (-) lead to the (-) terminal, and right to RIGHT and left to LEFT.

## GROUND (EARTH)

The GROUND screw terminal is provided on the rear panel to provide means for all equipment chassis to be at the same potential in a Hi-Fi installation.

## CONVENIENCE AC OUTLET

The outlets marked SWITCHED on the rear panel provide power and switching control to whatever component you may wish to connect to the unit. For example, if you connect the power cord of your record player to the outlet, the record player will be activated and deactivated by the power switch on the unit.

**Caution:** Do not connect components whose total power consumption exceeds maximum power rating marked on the outlets.



# All about the ROTEL RA-312



## Specifications

### POWER AMPLIFIER SECTION:

Continuous Power Output ..... 18 watts per channel, min. RMS, both channels driven into 8 ohms from 50 to 20,000 Hz with no more than 1% total harmonic distortion.

22 watts per channel, min. RMS, both channel driven into 8 ohms at 1 kHz with no more than 0.5% total harmonic distortion

Intermodulation Distortion ..... Less than 0.1% at rated output  
Frequency Response ..... 5 to 60,000 Hz,  $\pm 3$ dB at 1 watt per channel  
Square Wave Rise Time ..... 6 microseconds  
Damping Factor ..... 40 at 1 kHz

### Signal to Noise Ratio

(IHF, 'A' closed circuit network)

Phono 1, 2 ..... 70 dB  
Tape, Aux, Tuner ..... 90 dB  
Residual ..... 0.5 mV

### Input Sensitivity/Impedance (Rated output at 1 kHz)

Phono 1, 2 ..... 2.8 mV/47 kohms  
Tape ..... 150 mV/50 kohms  
Aux, Tuner ..... 150 mV/50 kohms

### Output Level

Tape out (RCA jack) ..... 280 mV/3.3 kohms  
Tape out (Din jack) ..... 105mV/ 75kohms  
Phono Overload ..... 110 mV  
Phono Equalization ..... R.I.A.A. STD  $\pm 1.0$  dB  
Bass Control .....  $\pm 10$  dB at 100 Hz  
Treble Control .....  $\pm 10$  dB at 10 kHz  
Loudness Control ..... +7 dB at 100 Hz, +3 dB at 10 kHz  
High Filter ..... 6 dB/Oct at 10 kHz  
Low Filter ..... 6 dB/Oct at 100 Hz  
Crosstalk ..... 45 dB (Overall)

### GENERAL INFORMATION

Power Consumption ..... MAX120W  
Dimensions (overall) ..... 400(W) x 110(H) x 240(D) mm  
Weight (net) ..... 6 Kg/ 13.2 lbs

## Block Diagrams

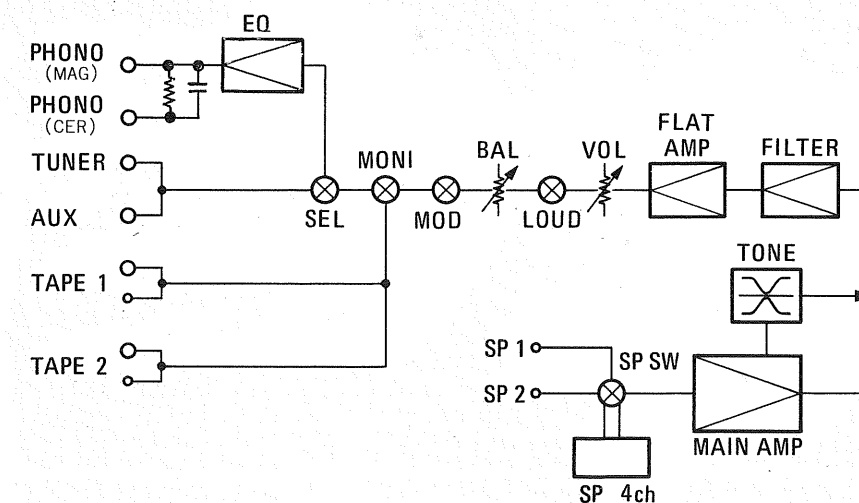

## Features & Function Controls

**SPEAKERS CONTROL** — allows you to select your speaker systems for activation. OFF to deactivate all speaker systems when such as listening to your headphones privately, 1 to activate your speaker systems connected to SPKR-1 terminals on the rear chassis; 2 to activate your systems connected to SPKR-2; 1+2 to activate both systems SPKR-1 and SPKR-2; SPKR 4CH to activate speaker matrix for simulated 4-channel sound using both SPKR-1 and SPKR-2 Systems.

**BASS CONTROL** — regulates low frequency sounds, as desired, to suit personal taste, speaker characteristics, etc. The center position gives normal (flat) frequency response. Rotating clockwise increases the bass, and counterclockwise reduces the bass. You may adjust the bass control for each channel simultaneously or individually. The outer ring adjusts the left channel and the inner knob adjusts the right channel. In order to adjust both channels turn both knobs together. In order to adjust one channel only, simply hold one knob while turning the other.

**BALANCE CONTROL** — regulates the relative sound outputs from each channel. Normally the control is adjusted to provide the effect of mono signal coming from a point midway between the speakers. When balanced in this way, the optimum stereo effect will be achieved. Rotate clockwise for increase in sound level from the right channel, and counter-clockwise for the left channel.

**TREBLE CONTROL** — regulates high frequency sounds, and operates in the same manner as the BASS CONTROL.

**MODE SWITCH** — selects between stereophonic and monophonic operation depending upon the program source. In ON position the program will be heard monophonic, and in OFF position it will be stereophonic. Normally, leave the switch in OFF position.

**MONITOR SWITCHES** — allows you to playback, monitor, and dub two tape recorders. TAPE 1 switch is used with the tape recorder connected to the TAPE MONITOR 1 terminals on the rear panel and TAPE 2 switch is for the tape recorder connected to the TAPE MONITOR 2 terminals. If you have the tape deck with DIN plug connected to the DIN socket on the rear panel, use TAPE 1 switch. Push in to MONITOR position to playback pre-recorded tapes, either TAPE 1 or TAPE 2 depending on which tape recorder you are using. When dubbing or duplicating the tape recorder connected to TAPE 2,

depress in TAPE 1 switch to MONITOR. Set both switches to SOURCE positions whenever tape recorder is not being operated but other program material is being played. If your tape recorders have separated playback heads, MONITOR positions also can be used as monitors during recording; setting to these positions will allow you to listen to program as actually being recorded. So, you can compare recording program playing (SOURCE position; off-the-tape or A-and-B monitoring) with same program being actually recorded on the tape (MONITOR position).

**POWER SWITCH** — performs the function as its name denotes. It supplies power to the unit and to any switched AC outlets. When the switch is ON the pilot light will be illuminated.

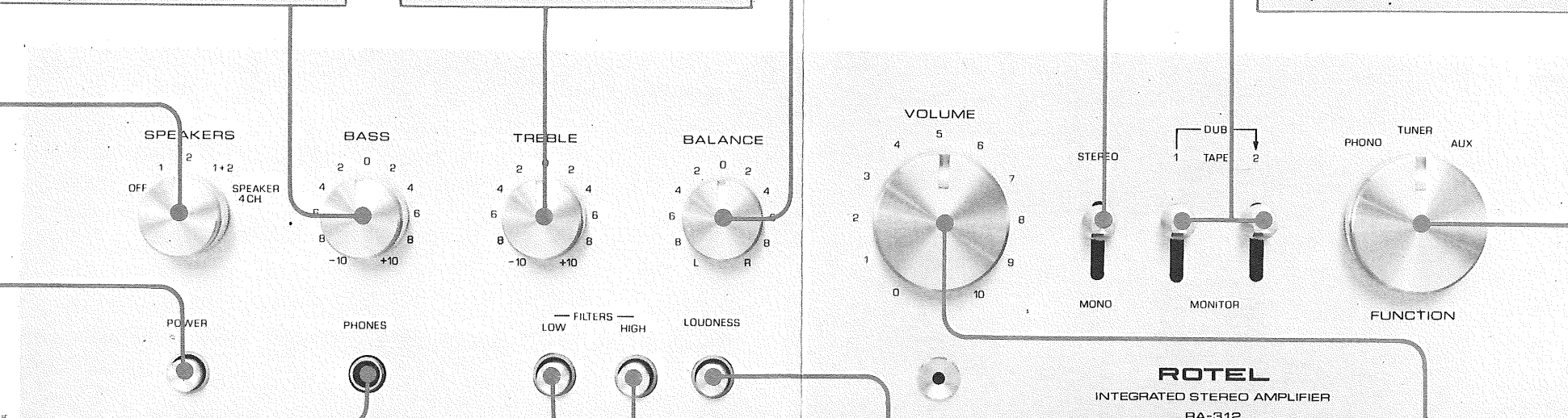

**HEADPHONES JACK** — simple plug in your stereo headphones lead to the receptacle for private listening. Turn to OFF the speakers control. If you are listening to the headphones only.

**LOW FILTER** — allows you to reduce the low frequency response of your unit whenever you wish to reduce annoying record and tape rumbles, etc.

**HIGH FILTER** — allows you to reduce high frequency interference whenever you wish to clear annoying record scratches, tape hiss, FM background noise, etc. Normally, however, keep this switch OFF for optimum frequency reproduction of all program sources.

**LOUDNESS SWITCH** — in ON position activates a circuit which boosts low and high frequency sounds at low volume control settings. This compensates for the ears loss of sensitivity to bass and treble notes at low listening levels. However, leave the switch OFF at normal and high volume settings to prevent booming noise or overload on some speakers.

**VOLUME CONTROL** — regulates the volume level of all channels simultaneously. Rotate the knob clock-wise to increase the volume and counterclockwise to decrease.

**FUNCTION SELECTOR CONTROL** — enables you to select the function you desire from PHONO TUNER and AUX.

## Additional Components

### COMPONENTS CONNECTIONS

This unit is designed to handle two record players with magnetic cartridges, two stereo tape recorders and two additional auxiliary components such as 8-track cartridge deck. We recommend that you familiarize yourself with basic operations before connecting any such units. Refer to the ADDITIONAL COMPONENTS section provided in this manual for connections and operations of these components.

### TURNTABLE

#### Connection

If your turntable comes with RCA-type plugs on output cables, connect them correctly to corresponding RIGHT and LEFT jacks of PHONO MAG inputs. If there is ground (earth) cable emerging from the turntable besides the output cables, connect it to the ground screw terminal marked GND or ⚡. If your turntable comes with a DIN plug on output cable, simply plug in to the DIN socket marked PHONO MAG.

If you need to use a ceramic type cartridge, connect the output cables of turntable to the terminal marked CER.

**NOTE:** To avoid loss of high frequency response due to excessively long output cables, shielded cables not exceeding 10 feet (3 meters) in length should be used to connect your turntable. Usually, cables supplied with your turntable are sufficient.

#### Operation

Turn the function selector control to PHONO and play your record disc, controlling volume and tone controls to suit your taste.

### TAPE RECORDER

#### Connection

A facility for tape recorder is referred to as TAPE MONITOR and is used in conjunction with the monitor switches on the front

panel. It is also used when your tape recorder has a separate playback head (i.e., tape recorder normally equipped with three heads).

Your tape recorder can be a reel-to-reel deck, a cassette recorder deck or a 8-track cartridge recorder deck.

If the tape recorder comes with RCA-type plugs, connect input cables to corresponding TAPE MONITOR jacks marked OUT and output cables to the jacks marked IN. Input jacks IN are for playing back pre-recorded tapes and output jacks OUT are for recording programs such as broadcasts, records and live sounds.

If the tape recorder comes with DIN plug, simply connect it to the DIN socket marked REC/PB at TAPE MONITOR 1.

### TAPE PLAYBACK

To listen to a playback of pre-recorded tape, flip either monitor switch to 1 or 2, depending on which TAPE MONITOR terminal the tape recorder is connected. The

setting of the function selector control is irrelevant in this case and may be left at any position.

### TAPE RECORDING

You may record with your tape recorder any program materials that can be played through this unit. Turn the function selector control to TUNER, PHONO or AUX depending on which program you wish to record, and operate the tape recorder while listening to the program.

Always leave the monitor switches off if your tape recorder has no separate playback head (look up its instruction manual to see if the tape recorder is equipped with separate playback and recording heads).

If your tape recorder is equipped with a separate playback head, turning the monitor control to 1 or 2 will cause the input source to be bypassed and will permit you to listen to the recording being made on the tape. Setting at the off position will permit you to listen to the input source. Thus, with the monitor control you may monitor or com-

pare the recording being made with the source being recorded. When dubbing, only the tape recorder that is recording will be monitored.

**NOTE:** You will not obtain any sound if either monitor switch is set at 1 or 2 unless the tape recorder has a separate playback head. Also, volume, bass, treble and balance controls of this unit will have no effect upon the recording, so you should use the controls on the tape recorder.

### TAPE DUBBING

To record off (dubbing) the tape recorder connected to TAPE 2, depress TAPE 1 switch to MONITOR, and operate both recorders. Note that you cannot dub the recorder connected to TAPE 1; it can be done if you plug the output cables of tape recorder connected to TAPE 2 to AUX terminals on the rear panel.

If your tape deck is equipped with a separated playback head, turning TAPE 1 or

TAPE 2 switch to MONITOR will cause the input source to be bypassed and will permit you to listen to the recording being made on the tape. When dubbing, only the tape recorder that is recording will be monitored; so pushing in TAPE 2 switch will let you monitor program being played back by TAPE 1.

### AUXILIARIES

#### 1. Connection

One set of AUX input terminals is provided for connection of equipment such as tape deck without recording facility (e.g., 8-track player deck). Connect the output cables of such equipment to input terminals in the same manner as the TAPE RECORDER section.

#### 2. Operation

Turn the function selector control to AUX. Adjust volume, balance, bass and treble controls to suit your personal tastes and listening conditions.

### SIMULATED 4-CHANNEL OPERATION

Two pairs of speakers are required to be set in one room for the simulated 4-channel operation, made possible by use of a special speaker matrix circuit built into this unit. Place the pair of speakers connected to the SPEAKER 1 terminals in the same manner as described above for the main speakers.

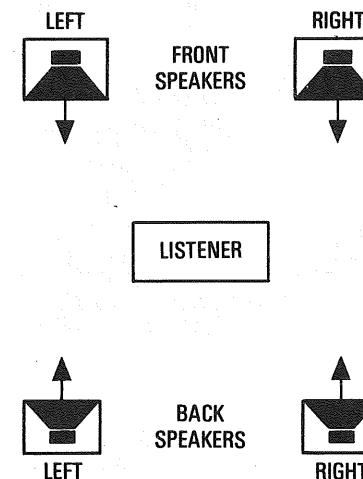
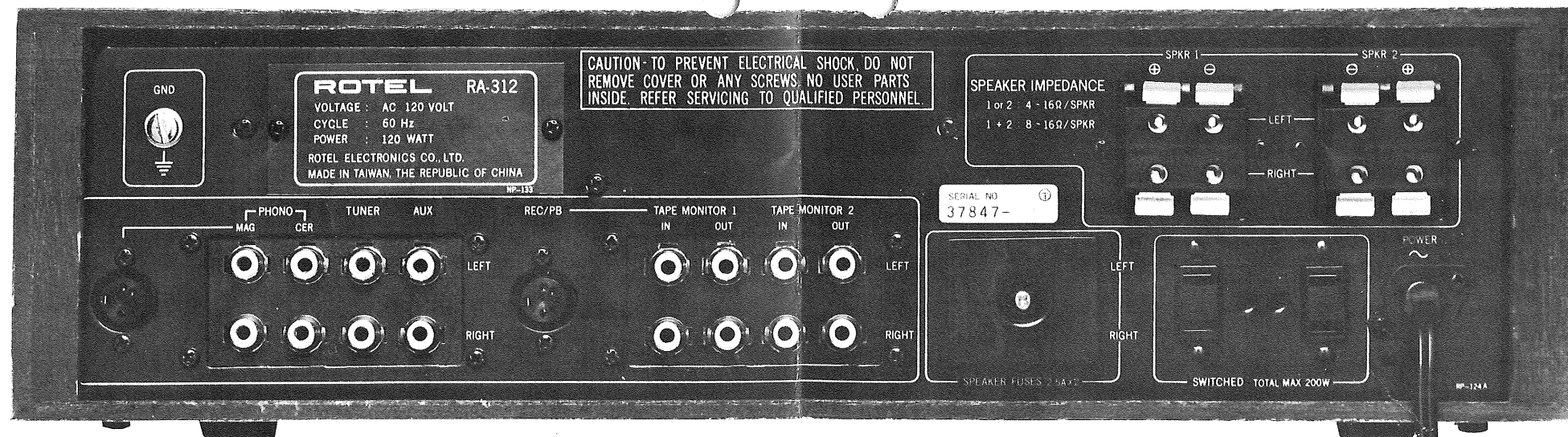

Fig. 3

They are referred to as the FRONT speakers. Placement of the other pair of speakers connected to the SPEAKER 2 terminals, referred to as the BACK speakers, will vary with your room size, seating arrangement and acoustic condition. It may be convenient to provide allowance on the length of speaker cables as later on you may wish to locate the BACK speakers differently from the initial position. We have suggested a common way of placing the BACK speakers as illustrated in Fig. 3, but you may arrange them in any way suit your tastes and listening conditions. Try some experimentations to locate optimum positions for best sound dispersion and ambience.



## HUM AND NOISE

In any high fidelity installation, hum may be caused by the interconnection of a record player, tuner and amplifier, and speakers as result of the cables, different grounds or locations of components. If hum is experienced with your unit, disconnect everything but the speakers from the unit. If the hum persists, reverse the power plug at the power source. Plug in the record player and if hum or howling appears, reverse the record player power plug or re-mount the record player away from the speakers as much as possible. Note hum may also be induced by defective connecting cables or by running these cables too close to a strong AC field.

When your unit picks up noises during the reception of broadcasts, causes are mostly due to external objects such as fluorescent lamps and house appliances using motor or thermostat, or others that may induce the noises. Either relocating the unit away from the noise sources or using an improved outdoor antenna may readily solve the problem. In the event you cannot find causes, consult your dealer or a qualified electrician.

## EXCLUSIVE NOTE FOR U.K.

If your unit comes with a 3-core cable without a plug, make certain live, neutral and (where appropriate) earth leads are connected to the proper terminals. Check that the terminals are screwed down firmly and no loose strands of wire are present.

**WARNING: THIS APPARATUS MUST BE EARTHED**

**IMPORTANT:** The wires in this mains lead are coloured in accordance with the following code:

GREEN/YELLOW: EARTH  
BLUE: NEUTRAL  
BROWN: LIVE

As the colours of the wires in the mains lead of this apparatus may not correspond with the coloured markings identifying the terminals in your plug proceed as follows.

The wire which is coloured GREEN/YELLOW must be connected to the terminal in the plug which is marked by the letter E or by the safety earth symbol , or coloured GREEN or GREEN/YELLOW.

The wire which is coloured BLUE must be connected to the terminal which is marked with the letter N or coloured BLUE or BLACK. The wire which is coloured BROWN must be connected to the terminal which is marked with the letter L or coloured BROWN or RED. The apparatus must be protected by a 3 Amp fuse if a 13 Amp (BS 1363) plug is used. If another type of plug is used a 5 Amp fuse or lower must be used, either in the plug or adapter or at the distribution board.

### Note:

- Features and specifications are subject to change without notice.
- When production design improvements are made there may be case(s) that having slightly different photographs and/or illustrations.

Roland Electronics Co., Ltd.: 1-36-8 Ohokayama, Meguro-ku, Tokyo, Japan  
Rotel Electronics Co., Ltd.: 310 Sec. 5, Nanking E Rd., Taipei, Taiwan

