

# ROTEL®

## OPERATING MANUAL

### SOLID STATE STEREO AMPLIFIER

### MODEL RA-110A

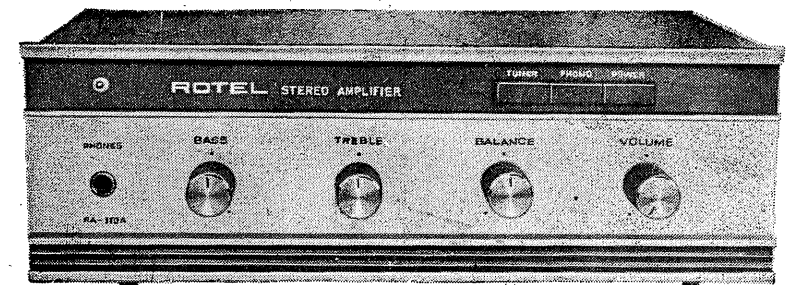

DISTRIBUTED BY

ROTEL OF AMERICA, INC.,

2642 CENTRAL PARK AVE., YONKERS, N.Y. 10710.  
13518 SOUTH NORMANPIE AVE., GARDENA, CALIF. 90249

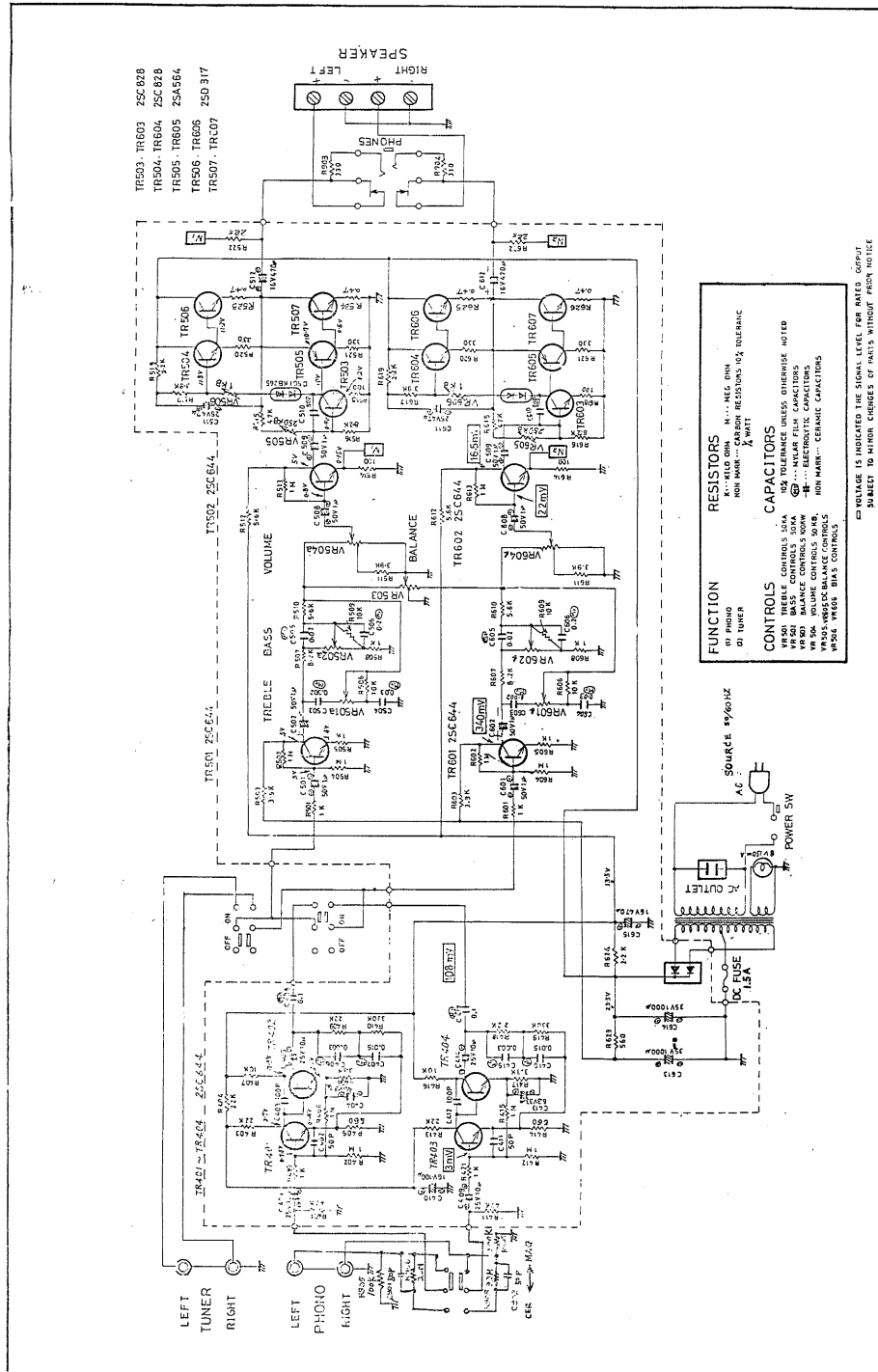

## FEATURES

THE ALL-TRANSISTOR STEREO AMPLIFIER MODEL RA-110A HAS SUCH QUALITY FEATURES AS 20 WATTS IHF MUSIC POWER, BASS AND TREBLE CONTROLS, FUSED OUTPUT STAGE AND AUXILIARY AC OUTLET.

THE MODEL RA-110A IS AN INTEGRATED PRE-MAIN STEREO AMPLIFIER,

## INSTALLATION

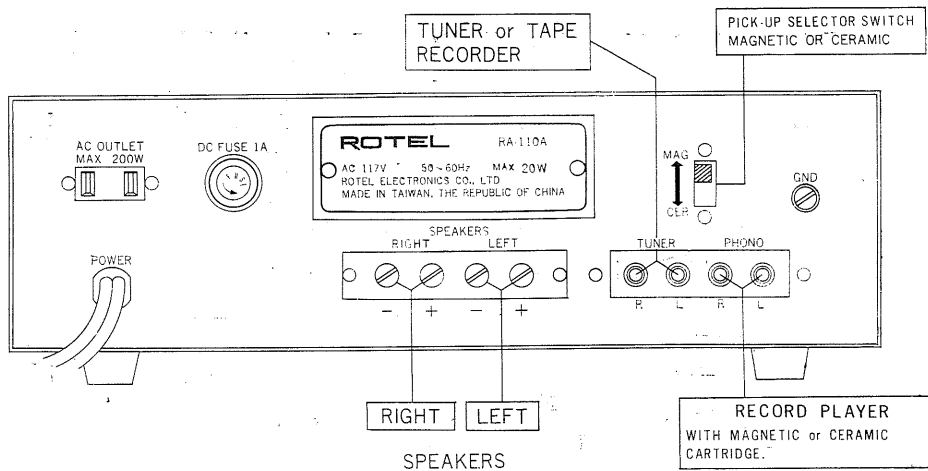

### SPEAKER CONNECTIONS:

Connect the left hand speaker leads to the terminals designated LEFT SPEAKER and the right speaker leads to RIGHT SPEAKER. Any speaker system of 4, 8, or 16 ohm impedance can be connected.

### WARNING:

Make sure that all the speaker leads are fastened securely to the proper terminals and that there are no stray strands shorting one terminal with adjacent terminal or the chassis.

### TUNER CONNECTIONS:

Use the TUNER terminals for connecting a tuner. In case of a Monophonic Tuner, connect the tuner output lead to either the RIGHT or LEFT terminal on the RA-110A by means of shielded cables.

### RECORD PLAYER CONNECTIONS:

Connect the outputs from a magnetic or ceramic type pick-up to the input jacks marked "PHONO"

## OPERATION

When all the connections have been made according to the preceding instructions, you may apply the power by pushing "IN" the POWER button.

### PHONO OPERATION:

Set the Selector to PHONO position and the MAG/CER switch to MAG. or CER, depending upon your pick-up.

The "BASS" and "TREBLE" controls may be set to your personal preference. Adjust the "BALANCE" control to obtain proper balance between the two speakers.

### TUNER OPERATION:

Set the SELECTOR to TUNER position and adjust all other controls as necessary for proper operation.

### PLAYBACK OF TAPE RECORDING:

To listen to a playback of pre-recorded tape, connect the output lead of tape recorder to the jack marked "TUNER" and set the ELECTOR to TUNER position.

### STEREO HEADPHONES:

Simply plug the lead from your headphones into the jack provided on the front panel. Speakers connected to this amplifier will be automatically disconnected.

### FUSE:

The model RA-110A has a fuse in the secondary circuit to prevent damage to the transistors. The rating of the fuse is 1 ampere. In the event of its failure, this fuse should be replaced with another of the same rating.

## SPECIFICATIONS

POWER SOURCE:	AC117V, 50/60 Hz.
POWER CONSUMPTION:	30 Watts
MUSIC POWER OUTPUT:	20 Watts at 4 ohms, 13 Watts at 8 ohms.
AUDIO DISTORTION:	0.5% at Maximum Output
HUM & NOISE:	Phono, 60 db, TUNER 60 db. RESIDUAL 2mv.
BASS CONTROL:	± 12db at 50 Hz
TREBLE CONTROL:	± 12db at 10,000 Hz
SPEAKER IMPEDANCE:	4, 8, 16 ohms.
DIMENSIONS:	11" (W) × 3 $\frac{3}{4}$ " (H) × 7 $\frac{1}{2}$ " (D)